

# Hardware Maintenance Manual

Lenovo  
YOGA

Lenovo

Yoga Pro 9i Aura Edition (16", 11)

**First Edition (January 2026)**

**© Copyright Lenovo 2026.**

LIMITED AND RESTRICTED RIGHTS NOTICE: If data or software is delivered pursuant to a General Services Administration "GSA" contract, use, reproduction, or disclosure is subject to restrictions set forth in Contract No. GS-35F-05925.

---

# Contents

<b>About this manual . . . . .</b>	<b>ii</b>
------------------------------------	-----------

<b>Chapter 1. Safety requirements for hardware maintenance . . . . .</b>	<b>1</b>
--------------------------------------------------------------------------	----------

General safety requirements . . . . .	1
Electrical safety requirements . . . . .	1
Safety inspection guide . . . . .	3
Handling devices that are sensitive to electrostatic discharge . . . . .	3
Important danger warning in multiple languages . . . . .	4

<b>Chapter 2. Diagnostics and troubleshooting . . . . .</b>	<b>17</b>
-------------------------------------------------------------	-----------

Diagnostics applications . . . . .	17
Hardware scan in Vantage . . . . .	17
UEFI diagnostics application . . . . .	18
Advanced diagnostics application (Windows version) . . . . .	18
Advanced diagnostics application (bootable versions for Linux/UEFI) . . . . .	18
Call Lenovo . . . . .	19
Before you contact Lenovo . . . . .	19
Lenovo Customer Support Center . . . . .	19
Nonwarranted items and activities . . . . .	20

<b>Chapter 3. Parts, screws, and tools . . . . .</b>	<b>21</b>
------------------------------------------------------	-----------

Parts . . . . .	21
Part type definition . . . . .	21
Look up a part . . . . .	22
Exploded view and part list . . . . .	22
Screws . . . . .	23
Screw list . . . . .	23
Screw notices . . . . .	24
Service tools . . . . .	25

<b>Chapter 4. Hardware replacement . . . . .</b>	<b>29</b>
--------------------------------------------------	-----------

General guidelines . . . . .	29
Lower case . . . . .	29

Label locations . . . . .	30
Battery pack and battery pack cable . . . . .	31
Wi-Fi card mylar . . . . .	32
M.2 solid-state drive . . . . .	33
M.2 2242 solid-state drive and SSD foil (for selected models) . . . . .	33
M.2 2280 solid-state drive (for selected models) . . . . .	34
PMIC board . . . . .	35
Type-C bracket . . . . .	36
Microphone board and microphone cable . . . . .	37
Force pad FFC1 and force pad FFC2 . . . . .	38
Thermal module . . . . .	38
Handling thermal interface materials . . . . .	40
I/O board and I/O FFC . . . . .	41
System board, I/O FPC and PMIC FFC . . . . .	43
Write key product information to a replacement system board . . . . .	46
Speakers . . . . .	46
Display assembly . . . . .	47
LCD Self Test . . . . .	49
Upper case . . . . .	50
Disassemble the display assembly . . . . .	50
Hinge cover . . . . .	50
Hinges . . . . .	51
Strip cover . . . . .	51
Panel, EDP cable and removable tapes . . . . .	52
Camera rubber . . . . .	53
Camera board . . . . .	54
Camera cable . . . . .	55
Panel cover . . . . .	55

<b>Appendix A. Important notice for Quebec consumers . . . . .</b>	<b>56</b>
--------------------------------------------------------------------	-----------

<b>Appendix B. Self-help resources . . . . .</b>	<b>57</b>
--------------------------------------------------	-----------

Trademarks . . . . .	.lix
----------------------	------

---

## About this manual

This manual contains hardware maintenance instructions for the products listed in the following table. In this manual, you will read safety requirements for hardware maintenance, diagnostics and troubleshooting, hardware replacement instructions, and other reference information. Use the manual along with the diagnostics applications and service tools to troubleshoot problems effectively.

Product name	Machine type (MT)
Yoga Pro 9 16IPH11	83SF

### Important:

- Hardware configurations and software programs vary by machine type. Some statements or illustrations in this manual might be slightly different from your computer.
- It is recommended that the computer be repaired by trained service technicians.
- For customers electing to service the computer on their own, it is still recommended to speak to our Customer Support Center so that you can be directed to the correct documentation and repair information. See “Call Lenovo” on page 19. Depending on the complexity of the repair, it may be recommended to have a Lenovo-authorized service provider repair your computer.
- Before servicing a computer, please follow all instructions carefully and be sure to read all the information under Chapter 1 “Safety requirements for hardware maintenance” on page 1 and “General guidelines” on page 29.

---

# Chapter 1. Safety requirements for hardware maintenance

This chapter presents the following safety information that you need to be familiar with before you service a Lenovo notebook computer.

---

## General safety requirements

Meet the following requirements on environment, personnel and outfit, and operation to ensure general safety:

### Environment requirements

Observe good housekeeping in the area of the machines during and after maintenance.

### Personnel and outfit requirements

- Do not wear loose clothing that can be trapped in the moving parts of a machine. Make sure that your sleeves are fastened or rolled up above your elbows. If your hair is long, fasten it.
- Insert the ends of your necktie or scarf inside clothing or fasten it with a non-conductive clip, about 8 centimeters (3 inches) from the end.
- Do not wear jewelry, chains, metal-frame eyeglasses, or metal fasteners for your clothing.

**Attention:** Metal objects are good electrical conductors.

- Wear safety glasses when you are hammering, drilling, soldering, cutting wire, attaching springs, using solvents, or working in any other conditions that might be hazardous to your eyes.

### Operation requirements

- Before you start the machine, make sure that no one is in a hazardous position.
- Do not perform any action that causes personal injury, or that makes the equipment unsafe.
- Keep your tool case away from walk areas so that other people will not trip over it.
- When lifting any heavy object:
  1. Make sure that you can stand safely without slipping.
  2. Distribute the weight of the object equally between your feet.
  3. Use a slow lifting force. Never move suddenly or twist when you attempt to lift.
  4. Lift by standing or by pushing up with your leg muscles; this action removes the strain from the muscles in your back. Do not attempt to lift any object that weighs more than 16 kg (35 lb) or that you think is too heavy for you.
- Place removed covers and other parts in a safe place, away from all personnel, while you are servicing the machine.
- After service, reinstall all safety shields, guards, labels, and ground wires. Replace any safety device that is worn or defective. Reinstall all covers correctly.
- Fan louvers on the machine help to prevent overheating of internal components. Do not obstruct fan louvers or cover them with labels or stickers.

---

## Electrical safety requirements

To ensure electrical safety, meet the following requirements on environment, outfit, and operation when working on the computer:

### Environment requirements

- Find the room emergency power-off (EPO) switch, disconnecting switch, or electrical outlet. If an electrical accident occurs, you can then operate the switch or unplug the power cord quickly.
- Do not work alone under hazardous conditions or near equipment that has hazardous voltages.

- Always look carefully for possible hazards in your work area. Examples of these hazards are moist floors, non-grounded power extension cables, power surges, and missing safety grounds.

### Outfit requirements

- Do not use worn or broken tools and testers.
- Regularly inspect and maintain your electrical hand tools for safe operational condition.

### Important:

- Use only approved tools and test equipment. Some hand tools have handles covered with a soft material that does not insulate you when working with live electrical currents.
- Many customers have, near their equipment, rubber floor mats that contain small conductive fibers to decrease electrostatic discharges. Do not use this type of mat to protect yourself from electrical shock.

### Operation requirements

- Disconnect all power before:
  - Performing a mechanical inspection
  - Working near power supplies
  - Removing or installing main units
- Do not service the following parts with the power on when they are removed from their normal operating places in a machine:
  - Power supply units
  - Pumps
  - Blowers and fans
  - Motor generators
  - Similar units as listed above
 This practice ensures correct grounding of the units.
- Electrical grounding of the computer is required for operator safety and correct system function. Proper grounding of the electrical outlet can be verified by a certified electrician.
- Observe the special safety precautions when you work with very high voltages; Instructions for these precautions are in the safety sections of maintenance information. Use extreme care when measuring high voltages.
- Before you start to work on the machine, unplug the power cord. If you cannot unplug it, ask the customer to power-off the wall box that supplies power to the machine, and to lock the wall box in the off position.
- Never assume that power has been disconnected from a circuit. First, check that it has been powered off.
- Do not touch live electrical circuits with the reflective surface of a plastic dental mirror. The surface is conductive; such touching can cause personal injury and machine damage.
- If you need to work on a machine that has exposed electrical circuits, observe the following precautions:
  - Ensure that another person, familiar with the power-off controls, is near you.

**Attention:** Another person must be there to switch off the power, if necessary.

- Use only one hand when working with powered-on electrical equipment; keep the other hand in your pocket or behind your back.

**Attention:** An electrical shock can occur only when there is a complete circuit. By observing the above rule, you may prevent a current from passing through your body.

- When using testers, set the controls correctly and use the approved probe leads and accessories for that tester.
- Stand on suitable rubber mats (obtained locally, if necessary) to insulate you from grounds such as metal floor strips and machine frames.
- If an electrical accident occurs:
  - Use caution; do not become a victim yourself.
  - Switch off power.
  - Send another person to get medical aid.

---

## Safety inspection guide

The purpose of this inspection guide is to assist you in identifying potentially unsafe conditions. As each machine was designed and built, required safety items were installed to protect users and service technicians from injury. This guide addresses only those items. You should use good judgment to identify potential safety hazards due to attachment of non-Lenovo features or options not covered by this inspection guide.

If any unsafe conditions are present, you must determine how serious the apparent hazard could be and whether you can continue without first correcting the problem.

Consider these conditions and the safety hazards they present:

- Electrical hazards, especially primary power (primary voltage on the frame can cause serious or fatal electrical shock)
- Explosive hazards, such as a damaged cathode ray tube (CRT) face or a bulging capacitor
- Mechanical hazards, such as loose or missing hardware

To determine whether there are any potentially unsafe conditions, use the following checklist at the beginning of every service task. Begin the checks with the power off, and the power cord disconnected.

Checklist:

1. Check exterior covers for damage (loose, broken, or sharp edges).
2. Power off the computer. Disconnect the power cord.
3. Check the power cord for:
  - a. A third-wire ground connector is in good condition. Use a meter to measure third-wire ground continuity for 0.1 ohm or less between the external ground pin and the frame ground.
  - b. The power cord should be the authorized type specified for your computer. Go to: <http://www.lenovo.com/serviceparts-lookup>
  - c. Insulation must not be frayed or worn.
4. Check for cracked or bulging batteries.
5. Remove the cover.
6. Check for any obvious non-Lenovo alterations. Use good judgment as to the safety of any non-Lenovo alterations.
7. Check inside the unit for any obvious unsafe conditions, such as metal filings, contamination, water or other liquids, or signs of fire or smoke damage.
8. Check for worn, frayed, or pinched cables.
9. Check that the power-supply cover fasteners (screws or rivets) have not been removed or tampered with.

---

## Handling devices that are sensitive to electrostatic discharge

Any computer part containing transistors or integrated circuits (ICs) should be considered sensitive to electrostatic discharge (ESD). ESD damage can occur when there is a difference in charge between objects. Protect against ESD damage by equalizing the charge so that the machine, the part, the work mat, and the person handling the part are all at the same charge.

**Notes:**

1. Use product-specific ESD procedures when they exceed the requirements noted here.
2. Ensure that the ESD protective devices you use have been certified (ISO 9000) as fully effective.

When handling ESD-sensitive parts:

- Keep the parts in protective packages until they are inserted into the product.
- Avoid contact with other people.
- Wear a grounded wrist strap against your skin to eliminate static on your body.
- Prevent the part from touching your clothing. Most clothing is insulative and retains a charge even when you are wearing a wrist strap.

- Use a grounded work mat to provide a static-free work surface. The mat is especially useful when handling ESD-sensitive devices.
- Select a grounding system, such as those listed below, to provide protection that meets the specific service requirement.

**Note:** The use of a grounding system to guard against ESD damage is desirable but not necessary.

- Attach the ESD ground clip to any frame ground, ground braid, or green-wire ground.
- When working on a double-insulated or battery-operated system, use an ESD common ground or reference point. You can use coax or connector-outside shells on these systems.
- Use the round ground prong of the ac plug on ac-operated computers.

---

## Important danger warning in multiple languages

The safety notices in this section are provided in the following languages:

- English
- Arabic
- Brazilian Portuguese
- French
- German
- Hebrew
- Japanese
- Korean
- Spanish
- Traditional Chinese

### English



#### DANGER

**Before the computer is powered on after FRU replacement, make sure that all screws, springs, and other small parts are in place and are not left loose inside the computer. Verify this by shaking the computer and listening for rattling sounds. Metallic parts or metal flakes can cause electrical short circuits.**



#### DANGER

**Some standby batteries contain a small amount of nickel and cadmium. Do not disassemble a standby battery, recharge it, throw it into fire or water, or short-circuit it. Dispose of the battery as required by local ordinances or regulations. Use only the battery in the appropriate parts listing. Use of an incorrect battery can result in ignition or explosion of the battery.**



#### DANGER

**The battery pack contains small amounts of nickel. Do not disassemble it, throw it into fire or water, or short-circuit it. Dispose of the battery pack as required by local ordinances or regulations. Use only the battery in the appropriate parts listing when replacing the battery pack. Use of an incorrect battery can result in ignition or explosion of the battery.**



## DANGER

The lithium battery can cause a fire, an explosion, or a severe burn. Do not recharge it, remove its polarized connector, disassemble it, heat it above 100°C (212°F), incinerate it, or expose its cell contents to water. Dispose of the battery as required by local ordinances or regulations. Use only the battery in the appropriate parts listing. Use of an incorrect battery can result in ignition or explosion of the battery.



## DANGER

If the LCD breaks and the fluid from inside the LCD gets into your eyes or on your hands, immediately wash the affected areas with water for at least 15 minutes. Seek medical care if any symptoms from the fluid are present after washing.



## DANGER

To avoid shock, do not remove the plastic cover that protects the lower part of the inverter card.



## DANGER

Though the main batteries have low voltage, a short-circuited or grounded battery can produce enough current to burn personnel or combustible materials.



## DANGER

Unless hot swap is allowed for the FRU being replaced, do as follows before removing it: power off the computer, unplug all power cords from electrical outlets, remove the battery pack, and disconnect any interconnecting cables.

## Arabic



قبل إعادة تشغيل الحاسب بعد الانتهاء من استبدال FRU، تأكد من أنه قد تم إعادة كل من المسامير و السوست وكل الأجزاء الصغيرة الأخرى في أماكنهم ولم يتم فقدهم داخل الحاسب. ويمكن التحقق من ذلك عن طريق هز الحاسب والاستماع لأي صوت صاخب يصدر منه. قد تؤدي الأجزاء أو الرقائق المعدنية إلى حدوث دائرة قصر.



تحتوي بعض البطاريات الاحتياطية على كمية صغيرة من مادتي النيكل والكادميوم. لا تقم بفك أو إعادة شحن البطارية الاحتياطية ولا تقم أيضا بالقاءها في النار أو الماء ولا تتسبب في احداث دائرة قصر بها. قم بالتخلص من البطارية كما هو موضح في القوانين المحلية. استخدم نوع البطارية المحدد والذي يوصى باستخدامه. حيث أنه قد يؤدي استخدام نوع بطارية غير صحيح الى اشتعالها أو انفجارها.



تحتوي حزمة البطارية على كمية صغيرة من مادة النيكل. لا تقم بفكها أو القاءها في النار أو الماء ولا تتسبب في احداث دائرة قصر بها. تخلص من حزمة البطارية وفقا لما هو موضح في القوانين المحلية. قم، عند استبدال حزمة البطارية، باستخدام الأنواع المحددة فقط والتي يوصى باستخدامها. حيث أنه قد يؤدي استخدام نوع بطارية غير صحيح الى اشتعالها أو انفجارها.



قد تتسبب بطارية الليثيوم في حدوث حريق أو انفجار أو حدوث حروق شديدة. لا تقم بإعادة شحن البطارية أو إزالة موصل الاستقطاب الخاص بها ولا تحاول أيضا فكها أو تسخينها لأكثر من ١٠٠ درجة مئوية (٢١٢ فهرنهايت) أو حرقها أو تعريض محتويات الخانة الخاصة بها للماء. قم بالتخلص من البطارية وفقا لما هو موضح في القوانين المحلية. استخدم نوع البطارية المحدد والذي يوصى باستخدامه. حيث أنه قد يؤدي استخدام نوع بطارية غير صحيح الى اشتعالها أو انفجارها.



إذا ما انكسرت شاشة LCD ولامس السائل الداخلي عينيك أو يديك، قم في الحال بغسلها بالماء لمدة لا تقل عن ١٥ دقيقة. إذا ما وجدت أي أعراض بعد الغسل اطلب عندئذ المساعدة الطبية.



لتجنب التعرض لأي صدمات، لا تقم بإزالة الغطاء البلاستيكي الذي يحمي الجزء الأسفل من بطاقة العاكس.



على الرغم من أن البطاريات الرئيسية يكون لها جهد منخفض، إلا أنه قد تقوم البطاريات التي حدث قصور بها أو التي تم توصيلها أرضيا بإصدار تيار يكفي لحدوث حروق للأفراد أو تعرض المواد القابلة للاشتعال للحريق.



ما لم يتم السماح بالتبديل الفوري لأي FRU الجاري استبداله بدون ضرورة اغلاق النظام، قم بتنفيذ ما يلي قبل ازالته. قم بإيقاف تشغيل الحاسب ونزع كل أسلاك الطاقة من المخارج الكهربائية وقم أيضا بإزالة حزمة البطارية ثم قم بفصل أي كابلات متصلة.

## Brazilian Portuguese



### PERIGO

Antes de ligar o computador após a substituição da FRU, certifique-se de que todos os parafusos, molas e outras peças pequenas estejam no lugar e não estejam soltos dentro do computador. Verifique isso sacudindo o computador e procurando ouvir sons de peças soltas. Peças metálicas ou lascas de metal podem causar curto-circuito.



### PERIGO

Algumas baterias reserva contêm uma pequena quantidade de níquel e cádmio. Não desmonte uma bateria reserva, recarregue-a, jogue-a no fogo ou na água, ou deixe-a entrar em curto-circuito. Descarte a bateria conforme requerido pelas leis ou regulamentos locais. Use somente a bateria nas partes listadas apropriadas. O uso de uma bateria incorreta pode resultar em combustão ou explosão da bateria.



### PERIGO

O pacote da bateria contém uma pequena quantidade de níquel. Não o desmonte, jogue-o no fogo ou na água, ou deixe-o entrar em curto-circuito. Descarte o pacote da bateria conforme requerido pelas leis ou regulamentos locais. Use somente a bateria nas partes listadas apropriadas ao substituir o pacote da bateria. O uso de uma bateria incorreta pode resultar em combustão ou explosão da bateria.



### PERIGO

A bateria de lítio pode causar incêndio, explosão ou graves queimaduras. Não a recarregue, remova seu conector polarizado, desmonte-a, aqueça-a acima de 100°C (212°F), incinere-a, ou exponha o conteúdo de sua célula à água. Descarte a bateria conforme requerido pelas leis ou regulamentos locais. Use somente a bateria nas partes listadas apropriadas. O uso de uma bateria incorreta pode resultar em combustão ou explosão da bateria.



### PERIGO

Se o LCD quebrar e o fluido de dentro dele entrar em contato com seus olhos ou com suas mãos, lave as áreas afetadas imediatamente com água durante pelo menos 15 minutos. Procure cuidados médicos se algum sintoma causado pelo fluido surgir após a lavagem.



## PERIGO

Para evitar choque elétrico, não remova a capa plástica que protege a parte inferior da placa inversora.



## PERIGO

Embora as principais baterias possuam baixa voltagem, uma bateria em curto-circuito ou aterrada pode produzir corrente o bastante para queimar materiais de pessoal ou inflamáveis.



## PERIGO

A menos que uma hot swap seja permitida para a FRU que está sendo substituída, faça o seguinte antes de removê-la: desligue o computador, desconecte todos os cabos de energia das tomadas, remova o pacote de baterias e desconecte quaisquer cabos de interconexão.

French



## DANGER

Avant de remettre l'ordinateur sous tension après remplacement d'une unité en clientèle, vérifiez que tous les ressorts, vis et autres pièces sont bien en place et bien fixées. Pour ce faire, secouez l'unité et assurez-vous qu'aucun bruit suspect ne se produit. Des pièces métalliques ou des copeaux de métal pourraient causer un court-circuit.



## DANGER

Certaines batteries de secours contiennent du nickel et du cadmium. Ne les démontez pas, ne les rechargez pas, ne les exposez ni au feu ni à l'eau. Ne les mettez pas en court-circuit. Pour les mettre au rebut, conformez-vous à la réglementation en vigueur. Lorsque vous remplacez la pile de sauvegarde ou celle de l'horloge temps réel, veillez à n'utiliser que les modèles cités dans la liste de pièces détachées adéquate. Une batterie ou une pile inappropriée risque de prendre feu ou d'exploser.



## DANGER

La batterie contient du nickel. Ne la démontez pas, ne l'exposez ni au feu ni à l'eau. Ne la mettez pas en court-circuit. Pour la mettre au rebut, conformez-vous à la réglementation en vigueur. Lorsque vous remplacez la batterie, veillez à n'utiliser que les modèles cités dans la liste de pièces détachées adéquate. En effet, une batterie inappropriée risque de prendre feu ou d'exploser.



## DANGER

La pile de sauvegarde contient du lithium. Elle présente des risques d'incendie, d'explosion ou de brûlures graves. Ne la rechargez pas, ne retirez pas son connecteur polarisé et ne la démontez pas. Ne l'exposez pas à une température supérieure à 100°C, ne la faites pas brûler et n'en exposez pas le contenu à l'eau. Mettez la pile au rebut conformément à la réglementation en vigueur. Une pile inappropriée risque de prendre feu ou d'exploser.



#### **DANGER**

Si le panneau d'affichage à cristaux liquides se brise et que vous recevez dans les yeux ou sur les mains une partie du fluide, rincez-les abondamment pendant au moins quinze minutes. Consultez un médecin si des symptômes persistent après le lavage.



#### **DANGER**

Afin d'éviter tout risque de choc électrique, ne retirez pas le cache en plastique protégeant la partie inférieure de la carte d'alimentation.



#### **DANGER**

Bien que le voltage des batteries principales soit peu élevé, le court-circuit ou la mise à la masse d'une batterie peut produire suffisamment de courant pour brûler des matériaux combustibles ou causer des brûlures corporelles graves.



#### **DANGER**

Si le remplacement à chaud n'est pas autorisé pour l'unité remplaçable sur site que vous remplacez, procédez comme suit avant de retirer l'unité : mettez l'ordinateur hors tension, débranchez tous les cordons d'alimentation des prises de courant, retirez le bloc de batterie et déconnectez tous les câbles d'interconnexion.

German



#### **VORSICHT**

Bevor nach einem FRU-Austausch der Computer wieder angeschlossen wird, muß sichergestellt werden, daß keine Schrauben, Federn oder andere Kleinteile fehlen oder im Gehäuse vergessen wurden. Der Computer muß geschüttelt und auf Klappergeräusche geprüft werden. Metallteile oder-splitter können Kurzschlüsse erzeugen.



#### **VORSICHT**

Die Bereitschaftsbatterie, die sich unter dem Diskettenlaufwerk befindet, kann geringe Mengen Nickel und Cadmium enthalten. Sie darf nur durch die Verkaufsstelle oder den IBM Kundendienst ausgetauscht werden. Sie darf nicht zerlegt, wiederaufgeladen, kurzgeschlossen, oder Feuer oder Wasser ausgesetzt werden. Die Batterie kann schwere Verbrennungen oder Verätzungen verursachen. Bei der Entsorgung die örtlichen Bestimmungen für Sondermüll beachten. Beim Ersetzen der Bereitschafts-oder Systembatterie nur Batterien des Typs verwenden, der in der Ersatzteilliste aufgeführt ist. Der Einsatz falscher Batterien kann zu Entzündung oder Explosion führen.



#### **VORSICHT**

Akkus enthalten geringe Mengen von Nickel. Sie dürfen nicht zerlegt, wiederaufgeladen, kurzgeschlossen, oder Feuer oder Wasser ausgesetzt werden. Bei der Entsorgung die örtlichen Bestimmungen für Sondermüll beachten. Beim Ersetzen der Batterie nur Batterien des Typs verwenden, der in der Ersatzteilliste aufgeführt ist. Der Einsatz falscher Batterien kann zu Entzündung oder Explosion führen.



#### **VORSICHT**

Die Systembatterie ist eine Lithiumbatterie. Sie kann sich entzünden, explodieren oder schwere Verbrennungen hervorrufen. Batterien dieses Typs dürfen nicht aufgeladen, zerlegt, über 100°C erhitzt oder verbrannt werden. Auch darf ihr Inhalt nicht mit Wasser in Verbindung gebracht oder der zur richtigen Polung angebrachte Verbindungsstecker entfernt werden. Bei der Entsorgung die örtlichen Bestimmungen für Sondermüll beachten. Beim Ersetzen der Batterie nur Batterien des Typs verwenden, der in der Ersatzteilliste aufgeführt ist. Der Einsatz falscher Batterien kann zu Entzündung oder Explosion führen.



#### **VORSICHT**

Die Leuchtstoffröhre im LCD-Bildschirm enthält Quecksilber. Bei der Entsorgung die örtlichen Bestimmungen für Sondermüll beachten. Der LCD-Bildschirm besteht aus Glas und kann zerbrechen, wenn er unsachgemäß behandelt wird oder der Computer auf den Boden fällt. Wenn der Bildschirm beschädigt ist und die darin befindliche Flüssigkeit in Kontakt mit Haut und Augen gerät, sollten die betroffenen Stellen mindestens 15 Minuten mit Wasser abgespült und bei Beschwerden anschließend ein Arzt aufgesucht werden.



#### **VORSICHT**

Aus Sicherheitsgründen die Kunststoffabdeckung, die den unteren Teil der Spannungswandlerplatine umgibt, nicht entfernen.



#### **VORSICHT**

Obwohl Hauptbatterien eine niedrige Spannung haben, können sie doch bei Kurzschluß oder Erdung genug Strom abgeben, um brennbare Materialien zu entzünden oder Verletzungen bei Personen hervorzurufen.



## VORSICHT

Wenn ein Austausch der FRU bei laufendem Betrieb nicht erlaubt ist, gehen Sie beim Austausch der FRU wie folgt vor: Schalten Sie den Computer aus, ziehen Sie alle Netzkabel von den Netzsteckdosen ab, entfernen Sie den Akku und ziehen Sie alle miteinander verbundenen Kabel ab.

## Hebrew



סכנה

לפני הפעלת המחשב לאחר החלפת FRU יש לוודא שכל הברגים, הקפיצים, וחלקים קטנים אחרים נמצאים במקומם ואינם חופשיים לזוז בתוך המחשב. כדי לוודא זאת, יש לטלטל את המחשב ולהקשיב לגילוי קולות שקשוק. חלקי או שבבי מתכת עלולים לגרום לקצרים חשמליים.



סכנה

סוללות המתנה מסוימות מכילות כמות קטנה של ניקל וקדמיום. אין לפרק סוללת המתנה, לטעון אותה מחדש, להשליך אותה לאש או למים או לקצר אותה. יש לסלק את הסוללה כנדרש על ידי התקנות והחוקים המקומיים. יש להשתמש רק בסוללה המופיעה ברשימת החלקים המתאימה. שימוש בסוללה לא מתאימה עלול לגרום להצתה או התפוצצות של הסוללה.



סכנה

מארז הסוללה מכיל כמות קטנה של ניקל וקדמיום. אין לפרק את מארז הסוללה, להשליך אותו לאש או למים או לקצר אותו. יש לסלק את מארז הסוללה כנדרש על ידי התקנות והחוקים המקומיים. יש להשתמש רק בסוללה המופיעה ברשימת החלקים המתאימה בזמן החלפת מארז הסוללה. שימוש בסוללה לא מתאימה עלול לגרום להצתה או התפוצצות של הסוללה.



סכנה

סוללת הליתיום עלולה לגרום לשריפה, להתפוצצות או לכוויות קשות. אין לטעון אותה מחדש, לסלק את המחבר המקוטב שלה, לפרק אותה או לחמם אותה לטמפרטורה העולה על 100 מעלות צלזיוס. אין לשרוף את הסוללה ואין לחשוף את תוכן התא למים. יש לסלק את הסוללה כנדרש בתקנות ובחוקים המקומיים. יש להשתמש רק בסוללה המופיעה ברשימת החלקים המתאימים. שימוש בסוללה אחרת עלול לגרום לסכנת שריפה או התפוצצות.



סכנה

אם מסך הנביש חנוזלי (LCD) נשבר וחנוזל מתוך המסך בא במגע עם עיניכם או ידיכם, שטפו את האזורים הנגועים מיד במשך 15 דקות לפחות. פנו לקבלת עזרה רפואית אם תסמינים חנובעים מחמגע עם חנוזל נמשכים לאחר השטיפה.



סכנה

כדי למנוע התחשמלות, אין להסיר את מכסה הפלסטיק המגן על חלקו התחתון של הכרטיס ההפוך.



סכנה

אף שהסוללות הראשיות הן בעלות מתח נמוך, סוללה מקוצרת או מוארכת עלולה להפיק זרם מספיק לגרימת כוויות או להצתת חומרים דליקים.



סכנה

אלא אם כן מותרת יחלפה חמו'י של ה-FRU המוחלף, פעלו כדלחלף לפני הסרתו :  
כבו את המחשב, נתקו את כל כבלי החשמל מהשקעים, הוציאו את מארר הסוללות ונתקו את כל הכבלים  
המחוברים.

## Japanese



### 危険

FRUの交換後、ThinkPadの電源を入れる前に、ねじ、バネ、その他の小さな部品がすべて正しい位置にあり、またThinkPadの内部で緩んでいないことを確認してください。  
これを確認するには、ThinkPadを振って、カチャカチャと音がしないか確かめます。金属部品や金属破片はショートの原因になることがあります。



### 危険

予備バッテリーの中には少量のニッケルとカドミウムが含まれているものがあります。したがって、予備バッテリーの分解、再充電、火または水の中への投棄、またはショートさせることは決して行わないでください。バッテリーを廃棄する場合は地方自治体の条例に従ってください。適切なパーツ・リストにあるバッテリーだけを使用してください。誤ったバッテリーを使用すると、バッテリーが発火したり、爆発したりすることがあります。



### 危険

バッテリー・パックには少量のニッケルが含まれています。バッテリー・パックを分解したり、火または水の中に投げ込んだり、ショートさせないでください。バッテリー・パックの廃棄にあたっては、地方自治体の条例または規則に従ってください。バッテリー・パックを交換するときは、適切なパーツ・リストにあるバッテリーだけを使用してください。誤ったバッテリーを使用すると、バッテリーが発火したり、爆発したりすることがあります。



### 危険

リチウム・バッテリーは、火災、爆発、または重症のやけどを引き起こすことがあります。バックアップ・バッテリーの充電、その極性コネクターの取り外し、バッテリー本体の分解、100°C (212°F) 以上への加熱、焼却、電池の中身を水に浸すことはしないでください。バッテリーを廃棄する場合は地方自治体の条例に従ってください。適切なパーツ・リストにあるバッテリーだけを使用してください。誤ったバッテリーを使用すると、バッテリーが発火したり、爆発したりすることがあります。



### 危険

LCDが破損し、LCDの中の液体が目に入ったり、手に触れたりした場合は、液体が触れた部分を少なくとも15分間洗い流してください。洗い流した後に、液体によって何らかの症状が現れた場合は、医師の治療を受けてください。



### 危険

感電を防ぐため、インバーター・カードの下部を保護しているプラスチック・カバーを外さないでください。



危険

メイン・バッテリーの電圧は低くても、ショートしたり、接地したバッテリーが、作業者にやけどを負わせたり、可燃物を燃やすだけの電流を発生させる場合があります。



危険

交換しようとしている FRU がホット・スワップに対応していない場合、それを取り外す前に、コンピューターの電源をオフにし、すべての電源コードをコンセントから抜き、バッテリー・パックを取り外して、相互接続しているケーブルをすべて切り離してください。

## Korean



위험

FRU를 교체하고 나서 컴퓨터 전원을 켜기 전에 모든 나사, 스프링 및 기타 작은 부품들이 올바른 위치에 있는지, 컴퓨터 내부에 단단하게 연결되어 있는지 확인하십시오. 컴퓨터를 흔들어 달걀거리는 소리가 나지 않는지 확인하십시오. 금속 부품 또는 금속 조각은 누전을 일으킬 수 있습니다.



위험

일부 보조 배터리에는 소량의 니켈 및 카드뮴이 포함되어 있습니다. 보조 배터리를 분해하거나, 다시 충전하거나, 불 또는 물에 던지거나, 단락시키지 마십시오. 배터리 팩을 폐기할 때에는 해당 지역의 법률 규정을 따르십시오. 배터리 팩을 교체할 때에는 올바른 배터리만 사용하십시오. 올바르지 않은 배터리를 사용하면 배터리가 발화되거나 폭발할 수 있습니다.



위험

배터리 팩에는 소량의 니켈이 포함되어 있습니다. 배터리 팩을 분해하거나, 불 또는 물에 던지거나, 단락시키지 마십시오. 배터리 팩을 폐기할 때에는 해당 지역의 법률 규정을 따르십시오. 배터리 팩을 교체할 때에는 올바른 배터리만 사용하십시오. 올바르지 않은 배터리를 사용하면 배터리가 발화되거나 폭발할 수 있습니다.



위험

리튬 배터리는 화재, 폭발 또는 심각한 화상을 일으킬 수 있습니다. 리튬 배터리를 다시 충전하거나, 극성 커넥터를 제거하거나, 분해하거나, 100C(212F) 이상으로 가열하거나, 소각하거나, 전지 내용물을 물에 노출시키지 마십시오. 배터리를 폐기할 때에는 해당 지역을 법률 규정을 따르십시오. 올바른 배터리만 사용하십시오. 올바르지 않은 배터리를 사용하면 배터리가 발화되거나 폭발할 수 있습니다.



위험

LCD가 파손되어 LCD 내부의 액체가 눈에 들어가거나 손에 묻으면 즉시 깨끗한 물로 15분 이상 닦아 내십시오. 씻은 후에 조금이라도 이상을 느끼면 즉시 병원에 가서 의사의 진찰을 받아야 합니다.



위험

전기적 위험을 방지하려면 인버터 카드의 아래 부분을 보호하는 플라스틱 덮개를 제거하지 마십시오.



위험

기본 배터리의 전압은 낮지만, 단락되거나 접지된 배터리는 화상을 입히기에 충분한 전류와 가연성 물질을 발생시킬 수 있습니다.



위험

FRU 교체 시 Hot Swap이 지원되지 않는 경우, FRU를 제거하기 전에 컴퓨터의 전원을 끄고, 전기 콘센트에서 전원 코드를 분리하고, 배터리를 제거한 후, 연결된 모든 케이블을 분리하십시오.

## Spanish



### PELIGRO

Antes de encender el sistema despues de sustituir una FRU, compruebe que todos los tornillos, muelles y demás piezas pequeñas se encuentran en su sitio y no se encuentran sueltas dentro del sistema. Compruébelo agitando el sistema y escuchando los posibles ruidos que provocarían. Las piezas metálicas pueden causar cortocircuitos eléctricos.



### PELIGRO

Algunas baterías de reserva contienen una pequeña cantidad de níquel y cadmio. No las desmonte, ni recargue, ni las eche al fuego o al agua ni las cortocircuite. Deséchelas tal como dispone la normativa local. Utilice sólo baterías que se encuentren en la lista de piezas. La utilización de una batería no apropiada puede provocar la ignición o explosión de la misma.



### PELIGRO

Las baterías contienen pequeñas cantidades de níquel. No las desmonte, ni recargue, ni las eche al fuego o al agua ni las cortocircuite. Deséchelas tal como dispone la normativa local. Utilice sólo baterías que se encuentren en la lista de piezas al sustituir la batería. La utilización de una batería no apropiada puede provocar la ignición o explosión de la misma.



## PELIGRO

La batería de repuesto es una batería de litio y puede provocar incendios, explosiones o quemaduras graves. No la recargue, ni quite el conector polarizado, ni la desmonte, ni caliente por encima de los 100°C (212°F), ni la incinere ni exponga el contenido de sus celdas al agua. Deséchela tal como dispone la normativa local.



## PELIGRO

Si la LCD se rompe y el fluido de su interior entra en contacto con sus ojos o sus manos, lave inmediatamente las áreas afectadas con agua durante 15 minutos como mínimo. Obtenga atención médica si se presenta algún síntoma del fluido después de lavarse.



## PELIGRO

Para evitar descargas, no quite la cubierta de plástico que rodea la parte baja de la tarjeta invertida.



## PELIGRO

Aunque las baterías principales tienen un voltaje bajo, una batería cortocircuitada o con contacto a tierra puede producir la corriente suficiente como para quemar material combustible o provocar quemaduras en el personal.



## PELIGRO

Salvo que se permita el intercambio en caliente para la unidad sustituible localmente, realice lo siguiente antes de extraerla: apague el sistema, desconecte todos los cables de alimentación de las tomas de alimentación eléctrica, extraiga la batería y desconecte los cables de interconexión.

### Traditional Chinese



## 危險

完成 FRU 更換之後，在開啟電腦的電源之前，請確定所有螺絲、彈簧及其他小零件都已歸位，沒有遺留在電腦內部。  
若要確認這一點，請搖晃電腦，聽聽看是否有卡嗒的聲響。  
金屬零件或儀錶的火花會造成電線短路。



## 危險

部分備用電池含有微量的鎳和鎘。請勿拆開備用電池、再充電、丟入火或水中，或使其形成短路。請按照當地法令或規定來棄置電池。

僅限使用零件清單中的電池。使用不適當的電池會導致電池起火或爆炸。



## 危險

電池套件含有微量的鎳。請勿拆開電池套件、丟入火或水中，或使其形成短路。請按照當地法令或規定來棄置電池套件。

更換電池套件時，僅限使用零件清單中的電池。使用不適當的電池會導致電池起火或爆炸。



危險

鋰電池會導致起火、爆炸或嚴重燒傷。請勿再充電、拔除其電極接頭、拆開、加熱超過 **100°C (212°F)**、焚燒，或讓電池組成物浸到水。請按照當地法令或規定來棄置電池。

僅限使用零件清單中的電池。使用不適當的電池會導致電池起火或爆炸。



危險

如果 LCD 破裂導致 LCD 流出的液體沾到您的眼睛或手，請立即以清水沖洗沾染部位至少 15 分鐘。如果在清洗後出現該液體所造成的任何症狀，請就醫治療。



危險

為避免電擊，請勿拆下轉換卡下面的塑膠護蓋。



危險

雖然主電池的電壓很低，但短路或接地電池所產生的電流，仍足以使人燒傷或使可燃物質起火。



危險

除非 FRU 允許以熱抽換來替換，否則請依下列方式將其移除：將電腦關機，拔除插座上所有電源線，移除電池包，並拔開任何交互連接的線材。

---

## Chapter 2. Diagnostics and troubleshooting

This chapter introduces several diagnostics applications to help you identify and solve the problems of your computer. If you still need help after running the applications, you can call Lenovo Customer Support Center.

---

### Diagnostics applications

The following table lists diagnostics applications available on your computer, their running environments, and brief introductions to each application.

Table 1. Diagnostics applications

Diagnostics application	Running environment	Brief introduction
“Hardware scan in Vantage” on page 17*	Run in the operating system.	The Vantage application is preinstalled on the computer. Hardware scan in the Vantage application is an effective hardware testing tool to help you identify the hardware problems of your computer.
“UEFI diagnostics application” on page 18*	Run in the UEFI BIOS.	A UEFI diagnostics application is preinstalled on the computer. This application enables you to view system information and test some hardware components in your computer, especially when you cannot start up the operating system.
<ul style="list-style-type: none"><li>• “Advanced diagnostics application (Windows version)” on page 18</li><li>• “Advanced diagnostics application (bootable versions for Linux/UEFI)” on page 18</li></ul>	Run in the operating system or boot from USB (Need download).	Advanced diagnostics applications help you test a wider scope of hardware components in your computer that cannot be covered by hardware scan in the Vantage application or the UEFI diagnostics application.

\* for selected models

**Important: Be extremely careful during such writing operations as copying, saving, or formatting.** Drives in the computer that you are servicing sequence might have been altered. If you select an incorrect drive, data or programs might be overwritten.

### Hardware scan in Vantage

To run the hardware scan in Vantage, do the following:

- Step 1. Launch the Vantage app.
- Step 2. Click **Hardware scan** or **Support Services → Hardware scan**.
- Step 3. Choose one of the following ways to run the hardware scan:

Click **Refresh Modules** and check the list of hardware components currently available in the computer. Select **QUICK SCAN** to test all the hardware components detected.

Select **CUSTOMIZE** to choose one or several hardware components to be tested.

- Step 4. If any hardware failure is detected, the result varies depending on the warranty status and varies by country or region. Follow the on-screen instructions to resolve the issue.

## UEFI diagnostics application

UEFI Diagnostics is consistently available as a boot option on Lenovo machines. To access the tool, follow these instructions:

- For ThinkPad, Thinkbook, and SMB systems, press the **F10** key during the boot process.
- For IdeaPad systems, access the **Novo button menu**, then select **Lenovo UEFI Diagnostics** from the menu. The application will start automatically.

The following table displays the items on the main screen of the UEFI diagnostics application. Depending on the model, the items might differ slightly.

Table 2. Items on the main screen of the UEFI diagnostics application

Category	Items
Tests	<ul style="list-style-type: none"><li>• Storage</li><li>• Memory</li><li>• CPU</li><li>• Display</li><li>• Motherboard</li><li>• Touch</li></ul>
Tools	<ul style="list-style-type: none"><li>• System Information</li><li>• Bad Block Recovery</li><li>• Smart Information</li></ul>

Prepare a USB flash drive formatted in FAT32. After the test is executed, select **View Log → Save Log**. The test log is saved in the USB flash drive. You can view the log to find possible solutions or send the log to Lenovo for helps.

## Advanced diagnostics application (Windows version)

To use the advanced diagnostics application (Windows version), do the following:

- Step 1. Go to <https://support.lenovo.com/solutions/ht506581>.
- Step 2. Select a Windows package that fits your scenario for download.
- Step 3. Double-click the downloaded file and complete the installation.
- Step 4. Launch the app and follow the on-screen instructions for diagnostics.

After the test is completed, select **Export Log** to save the diagnostic result. You can view the log to find possible solutions or send the log to Lenovo for helps.

## Advanced diagnostics application (bootable versions for Linux/UEFI)

To use the advanced diagnostics application (bootable versions for Linux/UEFI), do the following:

- Step 1. Prepare a USB flash drive larger than 2 GB and make a backup of the content in the USB flash drive. (During the following diagnosing process, the content in the USB flash drive content will be erased.)

**Note:** During the following diagnostic process, the content on the USB flash drive will be erased.

- Step 2. Go to <https://support.lenovo.com/solutions/bootableusb>.
- Step 3. Follow the on-screen instructions to create a bootable USB and run the application from the bootable USB.

After the test is executed, select **View Log** → **Export Log**. The test log is saved in the USB flash drive. You can view the log to find possible solutions or send the log to Lenovo for helps.

---

## Call Lenovo

If you have tried to correct the problem yourself and still need help, you can call Lenovo Customer Support Center.

## Before you contact Lenovo

Record product information and problem details before you contact Lenovo.

---

Product information	Problem symptoms and details
<ul style="list-style-type: none"><li>• Product name</li><li>• Machine type and serial number</li></ul>	<ul style="list-style-type: none"><li>• What is the problem? Is it continuous or intermittent?</li><li>• Any error message or error code?</li><li>• What operating system are you using? Which version?</li><li>• Which software applications were running at the time of the problem?</li><li>• Can the problem be reproduced? If so, how?</li></ul>

---

**Note:** The product name and serial number can usually be found on the bottom of the computer, either printed on a label or etched on the cover.

## Lenovo Customer Support Center

During the warranty period, you can call Lenovo Customer Support Center for help.

### Telephone numbers

For a list of the Lenovo Support phone numbers for your country or region, go to <https://pcsupport.lenovo.com/supportphonenumberlist>.

**Note:** Phone numbers are subject to change without notice. If the number for your country or region is not provided, contact your Lenovo reseller or Lenovo marketing representative.

### Services available during the warranty period

- Problem determination - Trained personnel are available to assist you with determining if you have a hardware problem and deciding what action is necessary to fix the problem.
- Lenovo hardware repair - If the problem is determined to be caused by Lenovo hardware under warranty, trained service personnel are available to provide the applicable level of service.
- Engineering change management - Occasionally, there might be changes that are required after a product has been sold. Lenovo or your reseller, if authorized by Lenovo, will make selected Engineering Changes (ECs) that apply to your hardware available.

### Services not covered

- Replacement or use of parts not manufactured for or by Lenovo or non-warranted parts
- Identification of software problem sources
- Configuration of UEFI/BIOS as part of an installation or upgrade
- Changes, modifications, or upgrades to device drivers
- Installation and maintenance of network operating systems (NOS)
- Installation and maintenance of programs

For the terms and conditions of the Lenovo Limited Warranty that apply to your Lenovo hardware product, see “Warranty information” in the *Safety and Warranty Guide* that comes with your computer.

## Nonwarranted items and activities

During the warranty period, the customer may be responsible for repair costs if the computer damage was caused by misuse, accident, modification, unsuitable physical or operating environment, or improper maintenance by the customer. Following is a list of some common items that are not covered under warranty and some symptoms that might indicate that the system was subjected to stress beyond normal use.

### Items not covered by warranty

- LCD panel cracked from the application of excessive force or from being dropped
- Scratched (cosmetic) parts
- Distortion, deformation, or discoloration of the cosmetic parts
- Plastic parts, latches, pins, or connectors that have been cracked or broken by excessive force
- Damage caused by liquid spilled into the system
- Damage caused by the improper insertion of a personal-computer card (PC card) or the installation of an incompatible card
- Improper disc insertion or use of an external optical drive
- Fuses blown by attachment of a non-supported device
- Forgotten computer password (making the computer unusable)
- Sticky keys caused by spilling a liquid onto the keyboard
- Use of an incorrect ac power adapter on laptop products

### Symptoms that might indicate damage caused by non-warranted activities

- Missing parts might be a symptom of improper service or modification.
- Check for obvious damage to a hard disk drive. If the spindle of a hard disk drive becomes noisy, the hard disk drive might have been dropped or subject to excessive force.

---

## Chapter 3. Parts, screws, and tools

---

### Parts

Before proceeding with part replacement, get to know part type definition, learn to look up a part on the Lenovo Support Web site, and gain an overview of all CRUs/FRUs in this computer through the exploded view.

### Part type definition

Your computer contains the following types of “Customer Replaceable Unit” (CRU)s and “Field Replaceable Unit” (FRU)s:

- **Self-service CRUs:** Refer to parts that can be replaced easily by customer themselves or by trained service technicians at an additional cost.
- **Optional-service CRUs:** Refer to parts that can be replaced by customers with a greater skill level. Trained service technicians can also provide service to replace the parts under the type of warranty designated for the customer’s product.
- **FRUs:** Refer to parts that are more complicated to replace and it is recommended that these parts should be replaced by trained service technicians. If customers elect to replace the FRU by themselves, we recommend that you ensure the correct instructions are carefully followed.

#### Important notes:

- **CRU statement for customers:**
  - You can resolve some problems with your product by replacing a CRU. For self-service CRUs, installation is your responsibility. For optional-service CRUs, you can either install the CRU yourself or you can request that a Service Provider install the CRU according to the warranty service for your product.
  - If you intend on installing the CRU, Lenovo will ship the CRU to you. CRU information and replacement instructions are shipped with your product and are available from Lenovo at any time upon request.
  - You can find a list of CRUs for your product in this *Hardware Maintenance Manual*. To find this manual, go to <https://support.lenovo.com> and search by product.
- **CRU/FRU statement:**
  - **Replace a CRU/FRU only with another CRU/FRU of the correct model.** When you replace a CRU/FRU, make sure that the model of the machine and the CRU/FRU part number are correct.
  - **A CRU/FRU should not be replaced because of a single unreproducible failure.** Single failures can occur for a variety of reasons that have nothing to do with a hardware defect, such as cosmic radiation, electrostatic discharge, or software errors. Consider replacing a CRU/FRU only when a problem recurs. If you suspect that a CRU/FRU is defective, clear the error log and run the test again. If the error does not recur, do not replace the CRU/FRU.
  - **Be careful not to replace a nondefective CRU/FRU.**
  - When you return a CRU/FRU, you must include the following information in the parts exchange form or parts return form that you attach to it:
    1. Name and phone number of service technician
    2. Date of service
    3. Date on which the machine failed
    4. Date of purchase
    5. Failure symptoms, error codes appearing on the display, and beep symptoms

6. Procedure index and page number in which the failing CRU/FRU was detected
7. Failing CRU/FRU name and part number
8. Machine type, model number, and serial number
9. Customer's name and address

## Look up a part

1. For more detailed CRU/FRU information, including part numbers, descriptions, and substitution part numbers, go to <https://support.lenovo.com/partslookup>.
2. Type the product name, the machine type or the serial number in the corresponding field to get a general CRU/FRU list.

## Exploded view and part list

By the exploded view and the part list, you can find the images, names, and types of all the CRU/FRUs of your computer.

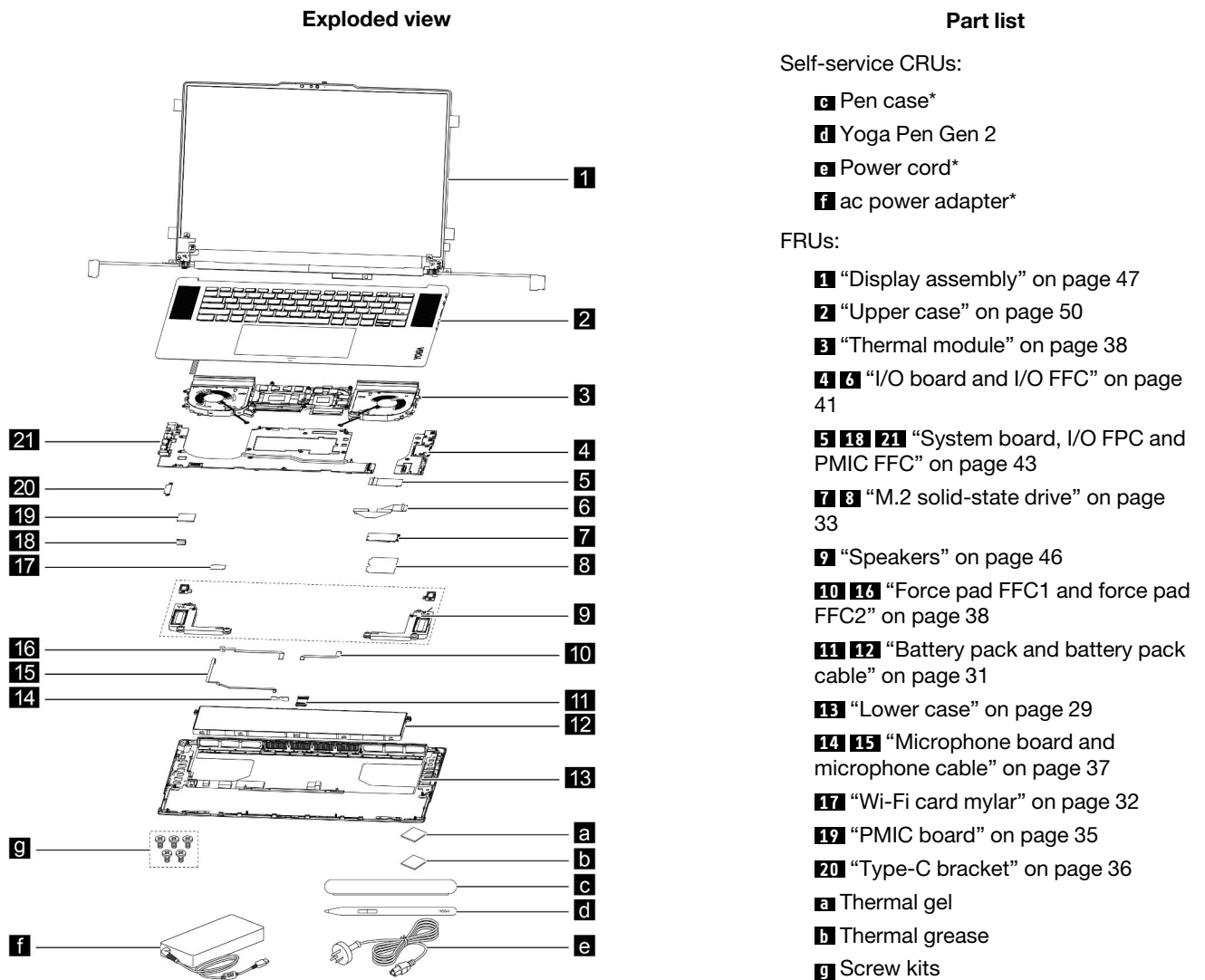

\* for selected models

## Exploded view

## Part list

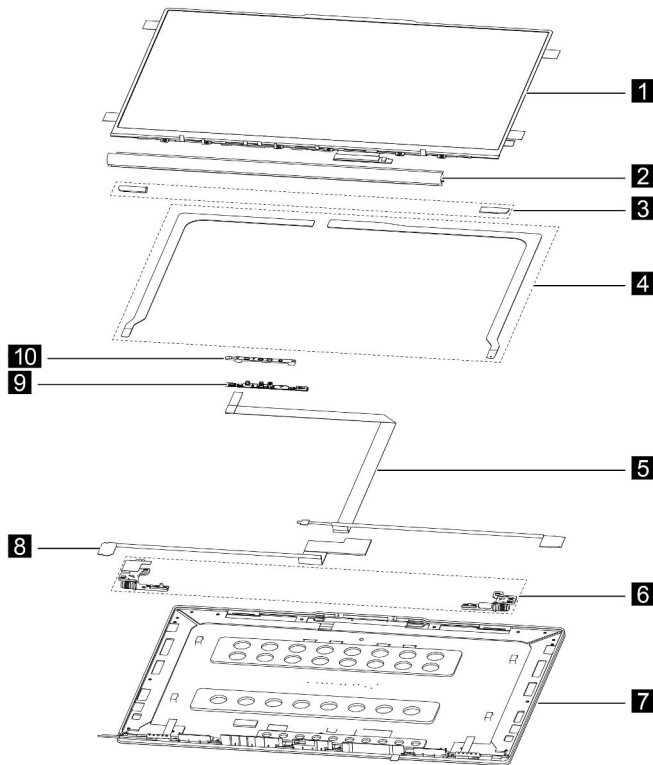

### FRUs:

- 1 4 8** “Panel, EDP cable and removable tapes” on page 52
- 2** “Hinge cover” on page 50
- 3** “Strip cover” on page 51
- 5** “Camera cable” on page 55
- 6** “Hinges” on page 51
- 7** “Panel cover” on page 55
- 9** “Camera board” on page 54
- 10** “Camera rubber” on page 53

## Screws

This section provides the screw list of this computer and the screw notices you need to know before hardware replacement.

## Screw list

The following table includes screw specifications, torque information, and screw colors of this product.

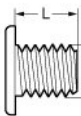

The number after the letter L refers to the length of the screw shank measured from under the head to the tip of the screw. The number after the letter M refers to the width of the screw shank measured across the outermost points in a metric screw.

Table 3. Screw list of this product

Thread (mm)	Length (mm)	Torque (kgf.cm)	Color
M1.6	L2.9	1.3 ± 0.15	Black
M1.6	L4	1.3 ± 0.15	Silver
M2	L2	1.85 ± 0.15	Black
M2	L3	1.85 ± 0.15	White
M2	L3.5	1.85 ± 0.15	Black

Table 3. Screw list of this product (continued)

Thread (mm)	Length (mm)	Torque (kgf.cm)	Color
M2	L5	<ul style="list-style-type: none"> <li>• 1.85 ± 0.15</li> <li>• 2.3 ± 0.15</li> </ul>	Silver
M2	L7.5	1.85 ± 0.15	Thunder grey
M2.5	L4.5	3.5 ± 0.3	Black

You can refer to the following table to choose a properly matched screwdriver.

**Notes:**



-  The Phillips head screw has a cross-shaped slot in the screw head.
-  The Torx head screw has a six-pointed star in the screw head.

Table 4. Choose a properly matched screwdriver

Screw head type	Thread (mm)	Screwdriver type
Phillips head	< M1.2	PH00
Phillips head	M1.6 – M2	PH0 or PH1
Phillips head	> M2	PH1
Torx head	M2	T5

## Screw notices

Do the following when you service the computer:

- Carefully retain and reuse all screws.
- Keep the screw kit in your tool bag. For the part number of the screw kit, go to: <https://support.lenovo.com/partslookup>.
- Use the correct screw as shown in the CRU/FRU replacement procedures.
- Turn the screws in the direction as given by the arrow in the CRU/FRU replacement illustration.
- If you have a torque screwdriver, tighten all screws firmly to the torque specified in the screw information table for each step.
- Ensure torque screwdrivers are calibrated correctly following country specifications.

Loose screws can cause a reliability problem. In your computer, this problem is addressed with special nylon-coated screws that have the following characteristics:

- They maintain tight connections.
- They do not easily come loose, even with shock or vibration.
- They are harder to tighten.

Tighten screws as follows:

- **Plastic to plastic**

Turn an additional angle of 90 degrees after the screw head touches the surface of the plastic part.

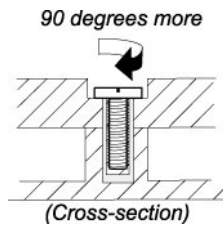

- **Logic card to plastic**

Turn an additional angle of 180 degrees after the screw head touches the surface of the logic card.

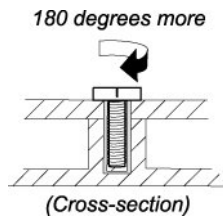

## Service tools

The following table lists all tools for servicing Lenovo products. Tools required to service a part are listed in the specific part disassembly topic. Prepare them before you service the product.

Table 5. Service tools



No.	Reference image	Tool name	Specification	Tool type
1		Screwdriver set	<ul style="list-style-type: none"> <li>• PH0, PH00, PH1, PH2</li> <li>• T5, T15, T20, T30</li> </ul> <p><b>Note:</b> Use a screwdriver with the shank length greater than 6 inches for Desktop, Workstation, and Smart device product.</p>	Common tool
2		Pry tool	N/A	Common tool
3		Tweezers	<ul style="list-style-type: none"> <li>• Conductive</li> <li>• Isolated</li> </ul>	Common tool
4		Suction cup	N/A	Common tool

Table 5. Service tools (continued)





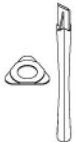



No.	Reference image	Tool name	Specification	Tool type
5		Hexagonal socket	<ul style="list-style-type: none"> <li>For VGA: H5 mm or H4.8 mm</li> <li>For Tiny antenna: H8 mm</li> </ul>	Common tool
6		Adjustable torque screwdriver	0.2 Nm to 4.0 Nm, Threadripper CPU, CAMM, etc	Common tool
7		ESD mat	N/A	Common tool
8		USB flash drive	For Golden Key, Chrome Reloads, AutoPilot, etc	Common tool
9		USB-C to USB-A converter	N/A	Common tool
10		Thermal pad	Variety of thickness, most common 0.5mm thickness pad under the component	Consumable tool
11		Thermal interface materials	N/A	Consumable tool
12		Acetate tape	N/A	Consumable tool
13		Polyimide tape	N/A	Consumable tool

Table 5. Service tools (continued)

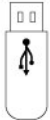









No.	Reference image	Tool name	Specification	Tool type
14		Mylar tape	N/A	Consumable tool
15		Electrical tape	N/A	Consumable tool
16		Double-sided tape	N/A	Consumable tool
17		Conductive tape	N/A	Consumable tool
18		Eraser	N/A	Consumable tool
19		Cleaning wipes	N/A	Consumable tool
20		Touchpad jig (this might come with touchpad)	N/A	Consumable tool
21		Heat gun	N/A	Special tool
22		Brown brush	25 mm to 35 mm wide	Special tool

Table 5. Service tools (continued)

No.	Reference image	Tool name	Specification	Tool type
23		Contact cleaner spray	WD-40 Contact cleaner for battery connector	Special tool
24		Hexagonal socket	H17 mm	Special tool

---

## Chapter 4. Hardware replacement

This chapter provides instructions on how to remove and install the hardware components of your computer.

---

### General guidelines



**Before removing any FRU or CRU, shut down the computer, unplug all power cords from electrical outlets, and wait about ten minutes to let the computer cool down.**

When removing or replacing a CRU/FRU, ensure that you observe the following general guidelines:

1. Before replacing any CRU/FRU, ensure that you have read [Generic Safety and Compliance Notices](#).
2. Begin by removing any CRUs/FRUs that have to be removed before replacing the failing CRU/FRU. Any such CRUs/FRUs are listed at the beginning of each CRU/FRU replacement procedure. Remove them in the order in which they are listed.
3. Follow the correct sequence in the steps for removing a CRU/FRU, as shown in the illustrations by the numbers in square callouts.
4. When removing a CRU/FRU, move it in the direction as shown by the arrow in the illustration.

#### Attention:

- After replacing a CRU/FRU, do not turn on the computer until you have ensured that all screws, springs, and other small parts are in place and none are loose inside the computer. Verify this by shaking the computer gently and listening for rattling sounds. Metallic parts or metal flakes can cause electrical short circuits.
- The system board is sensitive to and can be damaged by ESD. Before touching it, establish personal grounding by touching a ground point with one hand or by using an ESD strap (P/N 6405959).

---

### Lower case

- Before you start, ensure that you have read Chapter 1 “Safety requirements for hardware maintenance” on page 1 and “General guidelines” on page 29.
- Make sure the computer has been shut down before servicing the computer.

Step 1. Place the computer upside down on a flat surface.

Step 2. Remove ten screws.

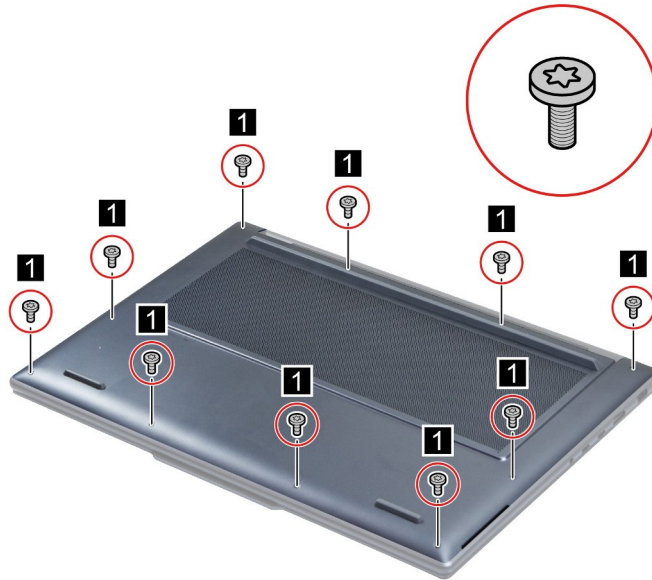

Figure 1. Remove ten screws

Table 6. Screws used to secure the lower case

Thread	Length (mm)	Torque (kgf.cm)	Quantity
M2	7.5	1.85±0.15	10

Step 3. Pry up the latches and remove the lower case.

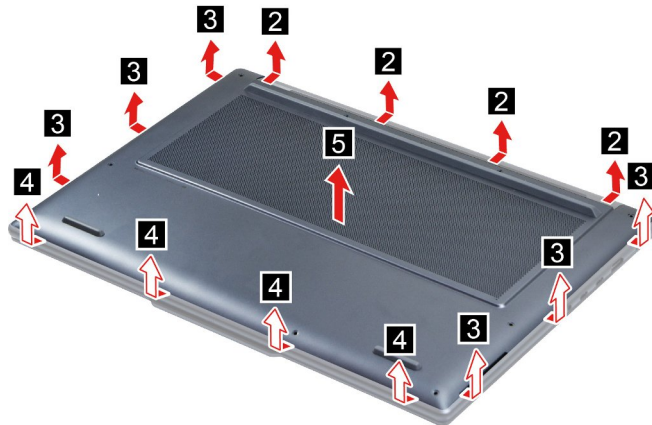

Figure 2. Remove the lower case

Step 4. Install the lower case in reverse order.

## Label locations

When replacing the base cover, reapply all labels that come with the replacement base cover. If some original labels are not included with the replacement base cover, peel them off from the original base cover and paste them on the replacement base cover.

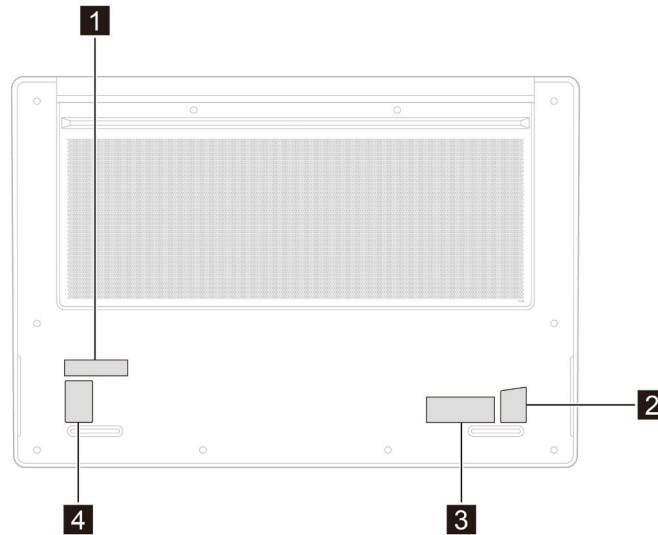

Figure 3. Label layout on the back side of the base cover

Labels attached to the base cover are country/region specific. Make sure to apply the appropriate labels to the replacement base cover.

Table 7. All base cover labels

Label	Label description	Applied country/region	Label dimensions
1	Country/region label	Indonesia	40 mm x 10 mm
2	OS label	All	16.1 mm x 22.5 mm
3	Carbon neutral label	All	43.1 mm x 16.2 mm
4	QR label + EAA QR label	EU	17 mm x 26.1 mm

## Battery pack and battery pack cable

- Before you start, ensure that you have read Chapter 1 “Safety requirements for hardware maintenance” on page 1 and “General guidelines” on page 29.
- Make sure the following FRU (or CRU) has been removed.

“Lower case” on page 29

Step 1. Disconnect the battery pack cable from the system board. Loosen two screws and then remove the battery pack.

**Attention:** Use your fingernails to pull the connector to unplug it. Do not pull the cable.

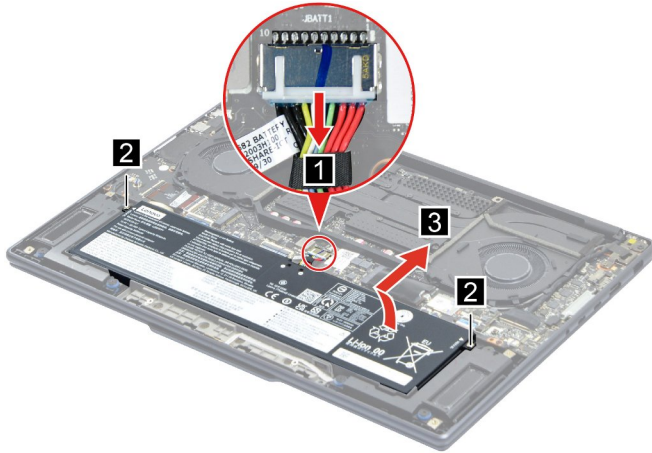

Figure 4. Remove the battery pack

Step 2. Remove the battery pack cable.

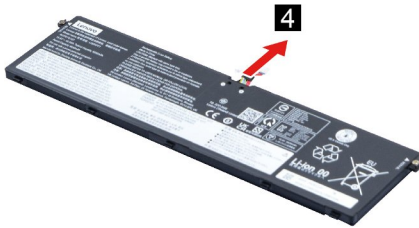

Figure 5. Remove the battery pack cable

Step 3. Install the battery pack and battery pack cable in reverse order.

---

## Wi-Fi card mylar

- Before you start, ensure that you have read Chapter 1 “Safety requirements for hardware maintenance” on page 1 and “General guidelines” on page 29.
- Make sure the following FRU (or CRU) has been removed.
  - “Lower case” on page 29

Step 1. Disconnect the battery pack cable from the system board, and then remove the Wi-Fi card mylar.

**Attention:** Use your fingernails to pull the connector to unplug it. Do not pull the cable.

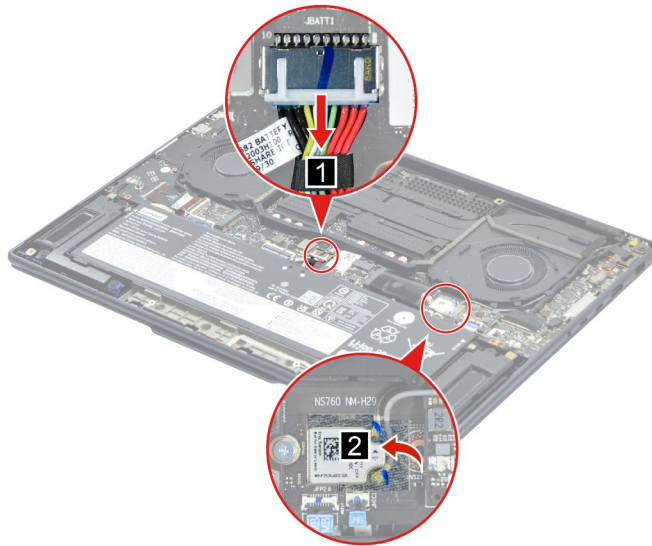

Figure 6. Remove the Wi-Fi card mylar

Step 2. Install the Wi-Fi card mylar in reverse order.

---

## M.2 solid-state drive

### M.2 2242 solid-state drive and SSD foil (for selected models)

- Before you start, ensure that you have read Chapter 1 “Safety requirements for hardware maintenance” on page 1 and “General guidelines” on page 29.
- Make sure the following FRU (or CRU) has been removed.

“Lower case” on page 29

Step 1. Disconnect the battery pack cable from the system board. Remove one screw and then remove the 2242 solid-state drive by pulling it away from the slot.

**Attention:** Use your fingernail to pull the connector to unplug it. Do not pull the cable.

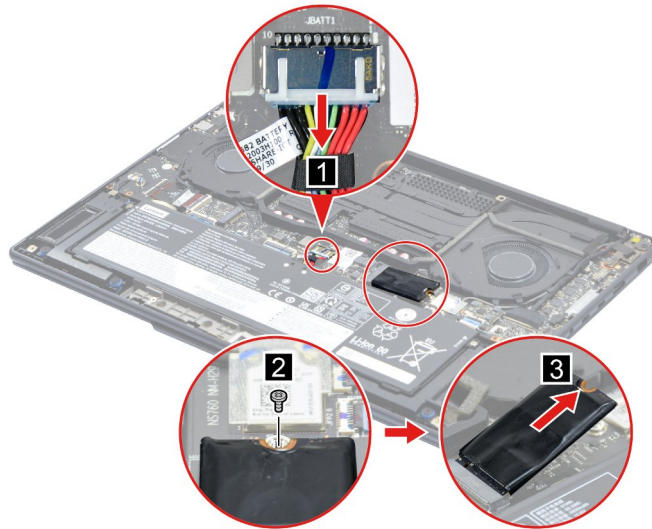

Figure 7. Remove the 2242 solid-state drive

Table 8. Screw used to secure the 2242 solid-state drive

Thread	Length (mm)	Torque (kgf.cm)	Quantity
M2	3	1.85 ± 0.15	1

Step 2. Remove the SSD foil from the 2242 solid-state drive.

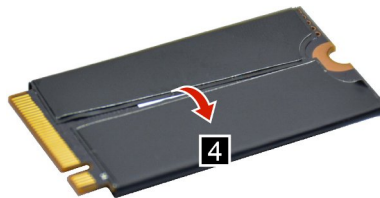

Figure 8. Remove the SSD foil

Step 3. Install the 2242 solid-state drive and SSD foil in reverse order.

## M.2 2280 solid-state drive (for selected models)

- Before you start, ensure that you have read Chapter 1 “Safety requirements for hardware maintenance” on page 1 and “General guidelines” on page 29.
- Make sure the following FRU (or CRU) has been removed.

“Lower case” on page 29

Step 1. Disconnect the battery pack cable from the system board, and then remove one screw.

**Attention:** Use your fingernail to pull the connector to unplug it. Do not pull the cable.

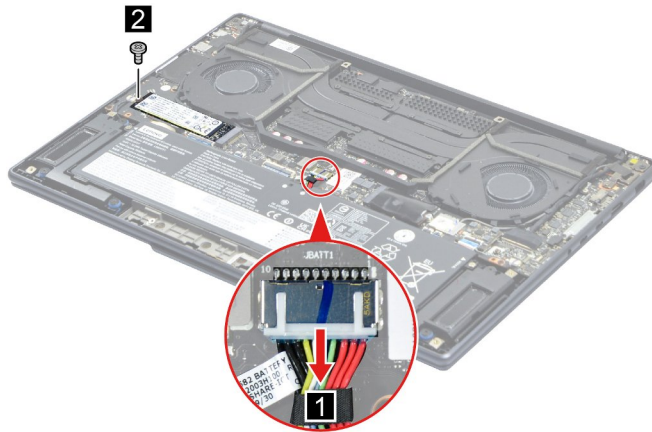

Figure 9. Remove one screw

Table 9. Screw used to secure the 2280 solid-state drive

Thread	Length (mm)	Torque (kgf.cm)	Quantity
M2	3	1.85 ± 0.15	1

Step 2. Remove the 2280 solid-state drive by pulling it away from the slot.

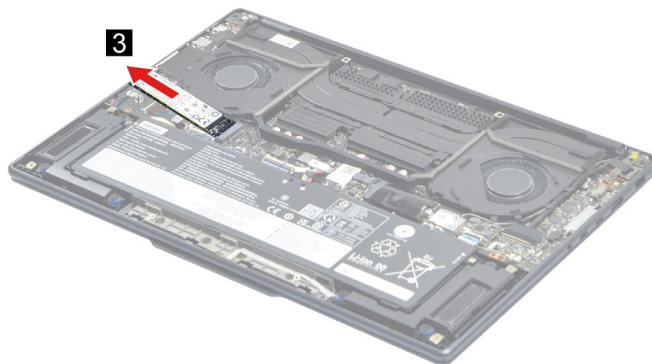

Figure 10. Remove the 2280 solid-state drive

Step 3. Install the 2280 solid-state drive in reverse order.

## PMIC board

- Before you start, ensure that you have read Chapter 1 “Safety requirements for hardware maintenance” on page 1 and “General guidelines” on page 29.
- Make sure the following FRU (or CRU) has been removed.  
“Lower case” on page 29

Step 1. Disconnect the battery pack cable from the system board. Disconnect the PMIC cable from the PMIC board and then remove the PMIC board.

**Attention:** Use your fingernails to pull the connector to unplug it. Do not pull the cable.

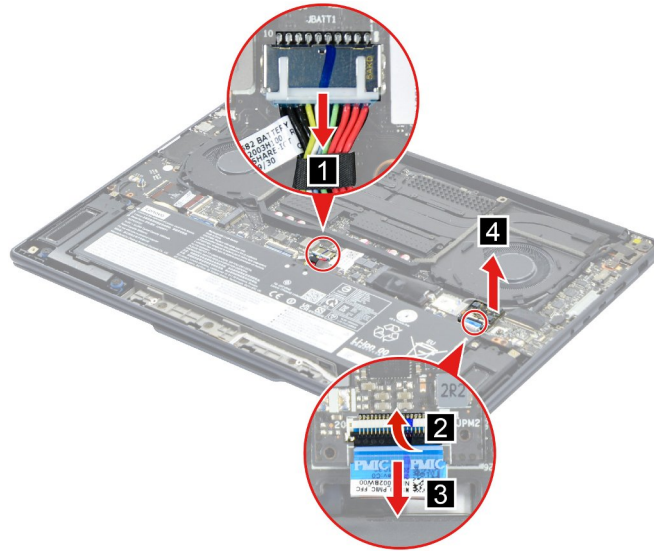

Figure 11. Remove the PMIC board

Step 2. Install the PMIC board in reverse order.

## Type-C bracket

- Before you start, ensure that you have read Chapter 1 “Safety requirements for hardware maintenance” on page 1 and “General guidelines” on page 29.
- Make sure the following FRU (or CRU) has been removed.  
“Lower case” on page 29

Step 1. Disconnect the battery pack cable from the system board. Remove two screws and then remove the Type-C bracket.

**Attention:** Use your fingernails to pull the connector to unplug it. Do not pull the cable.

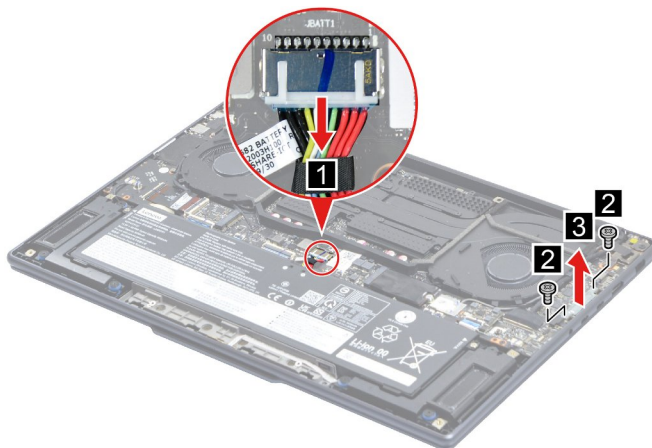

Figure 12. Remove the Type-C bracket

Table 10. Screws used to secure the Type-C bracket

Thread	Length (mm)	Torque (kgf.cm)	Quantity
M2	3.5	1.85 ± 0.15	2

Step 2. Install the Type-C bracket in reverse order.

## Microphone board and microphone cable

- Before you start, ensure that you have read Chapter 1 “Safety requirements for hardware maintenance” on page 1 and “General guidelines” on page 29.
- Make sure the following FRUs (or CRUs) have been removed.

“Lower case” on page 29

“Battery pack and battery pack cable” on page 31

Step 1. Disconnect the microphone cable from the system board and then remove the microphone board with cable.

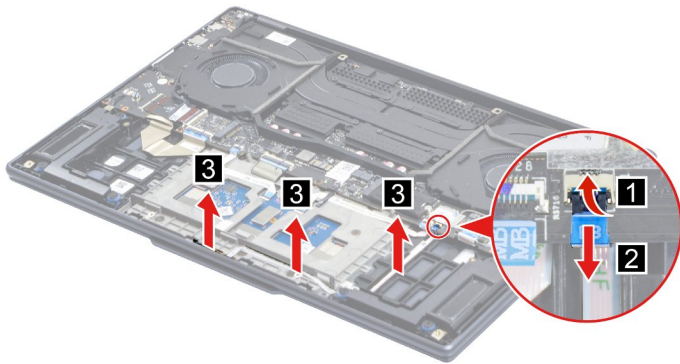

Figure 13. Remove the microphone board with cable

Step 2. Remove the microphone cable from the microphone board.

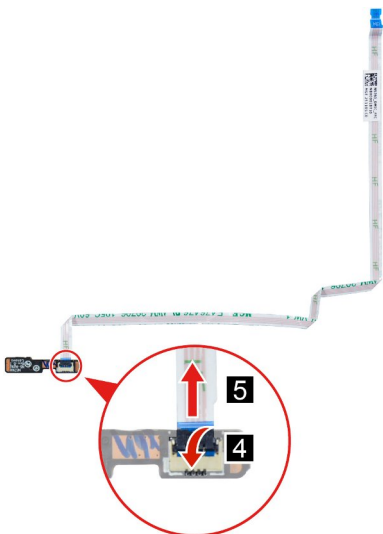

Figure 14. Remove the microphone cable

Step 3. Install the microphone board and microphone cable in reverse order.

---

## Force pad FFC1 and force pad FFC2

- Before you start, ensure that you have read Chapter 1 “Safety requirements for hardware maintenance” on page 1 and “General guidelines” on page 29.
- Make sure the following FRUs (CRUs) have been removed.
  - “Lower case” on page 29
  - “Battery pack and battery pack cable” on page 31

Step 1. Disconnect the force pad FFC1 from the system board and the force pad, and then remove the force pad FFC1.

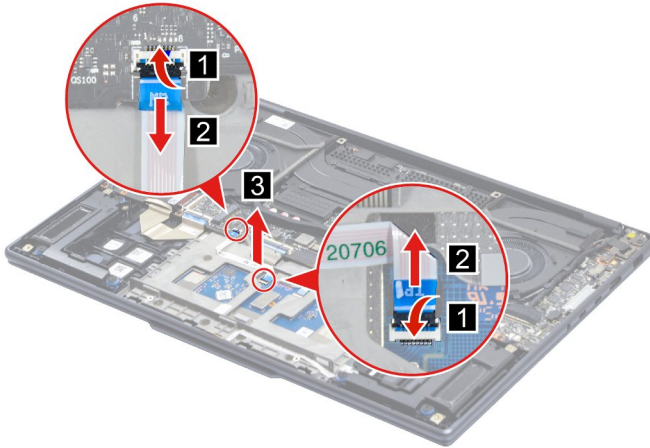

Figure 15. Remove the force pad FFC1

Step 2. Disconnect the force pad FFC2 from the system board and the force pad, and then remove the force pad FFC2.

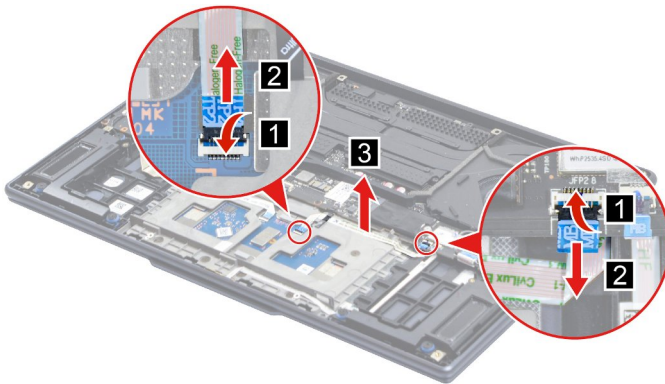

Figure 16. Remove the force pad FFC2

Step 3. Install the force pad FFC1 and force pad FFC2 in reverse order.

---

## Thermal module

- Before you start, ensure that you have read Chapter 1 “Safety requirements for hardware maintenance” on page 1 and “General guidelines” on page 29.
- Make sure the following FRUs (or CRUs) have been removed.

“Lower case” on page 29

“M.2 2242 solid-state drive and SSD foil (for selected models)” on page 33

Step 1. Peel off two tapes and release the cables from cable guides. Then, disconnect two fan cables from the system board.

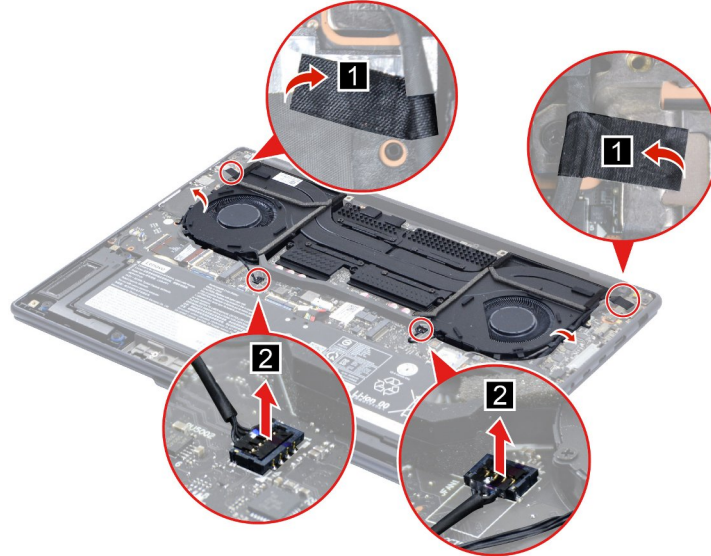

Figure 17. Disconnect two fan cables from the system board

Step 2. Remove six screws and loosen six screws in the alphabetical order. Then, remove the thermal module.

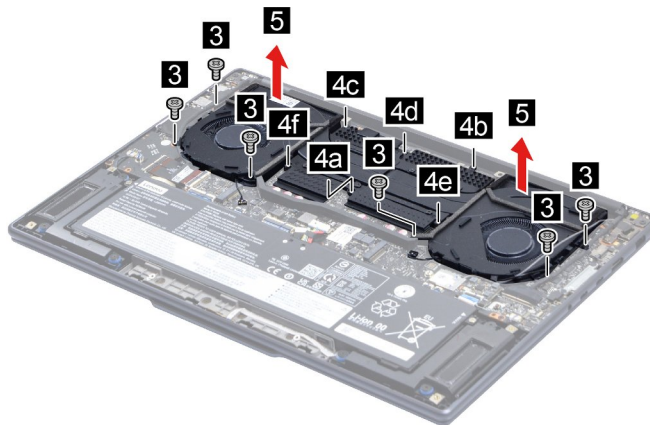

Figure 18. Remove the thermal module

Table 11. Screws used to secure the thermal module

Thread	Length (mm)	Torque (kgf.cm)	Quantity
M1.6	4	1.3 ± 0.15	6

Step 3. Install the thermal module in reverse order.

## Handling thermal interface materials

Thermal interface materials are typically applied between a heat sink and a CPU (and/or GPU) die to enhance the heat transfer capability of the heat sink. If thermal interface materials are exposed during computer servicing, such as when replacing the heat sink or system board, it is important to handle the thermal interface materials properly.

- You need to completely remove the old thermal interface materials from the CPU and/or GPU die.
- You need to apply new thermal interface materials onto the heat sink according to the type, quantity, and application areas specified in this publication.

### Related topics

“Thermal module” on page 38

“System board, I/O FPC and PMIC FFC” on page 43

### Type, quantity, and areas of thermal interface materials application on the heat sink

The table and figure below provide information on the type and quantity of thermal interface materials, as well as the specific areas on the heat sink where these materials should be applied.

Area	Type	Quantity
<b>a</b>	PTM7958	21 mm × 18 mm × 0.2 mm
<b>b</b>	PTM7958	16 mm × 16 mm × 0.2 mm
<b>c</b>	TC7004	14.2 mm × 12.2 mm × 1.1 mm
<b>d</b>	TC7004	14.2 mm × 12.2 mm × 1.1 mm
<b>e</b>	TC7004	13 mm × 10.5 mm × 1.5 mm

**Note:** Type TC7004 can be replaced by Type TC7006 during computer servicing.

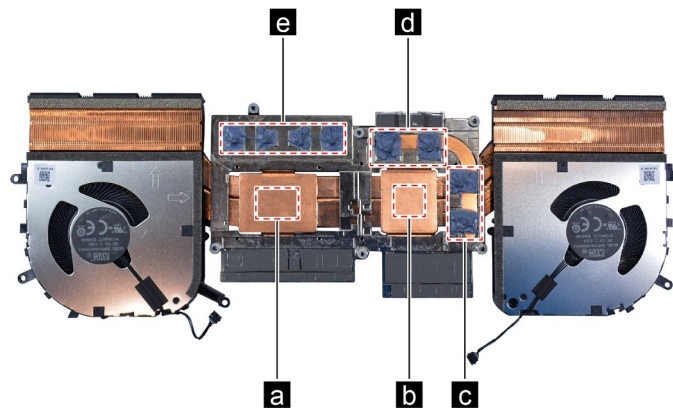

Figure 19. Areas on the heat sink where thermal interface materials should be applied

### Areas on the system board where thermal interface materials are applied

The following figure shows the areas on the system board where thermal interface materials are applied.

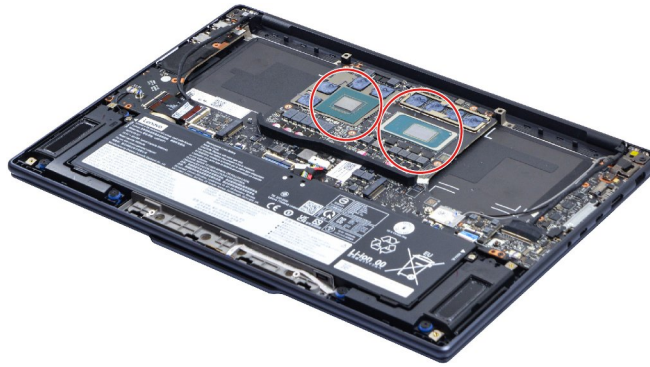

Figure 20. Areas on the system board where thermal interface materials are applied

## I/O board and I/O FFC

- Before you start, ensure that you have read Chapter 1 “Safety requirements for hardware maintenance” on page 1 and “General guidelines” on page 29.
- Make sure the following FRUs (or CRUs) have been removed.
  - “Lower case” on page 29
  - “Battery pack and battery pack cable” on page 31
  - “M.2 solid-state drive” on page 33
  - “Thermal module” on page 38

Step 1. Remove three screws and then open the hinge.

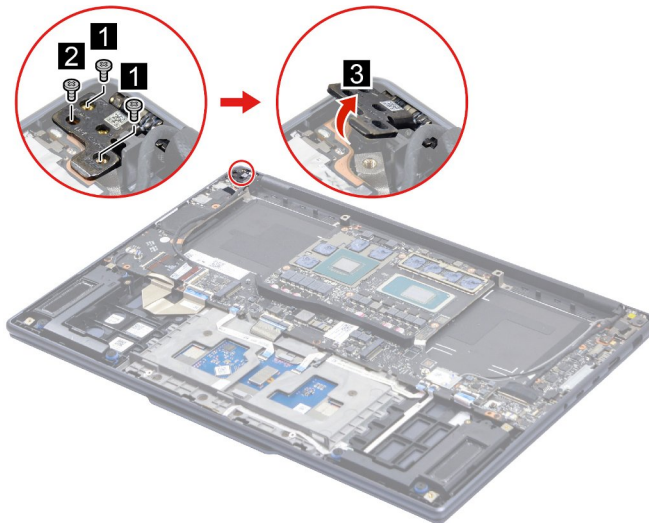

Figure 21. Remove three screws and open the hinge

Table 12. Screws used to secure the hinge

Label	Thread	Length (mm)	Torque (kgf.cm)	Quantity
<b>1</b>	M2.5	4.5	3.5 ± 0.3	2
<b>2</b>	M2	5	2.3 ± 0.15	1

Step 2. Disconnect the speaker cable and I/O FPC from the I/O board and disconnect the I/O FFC from the system board.

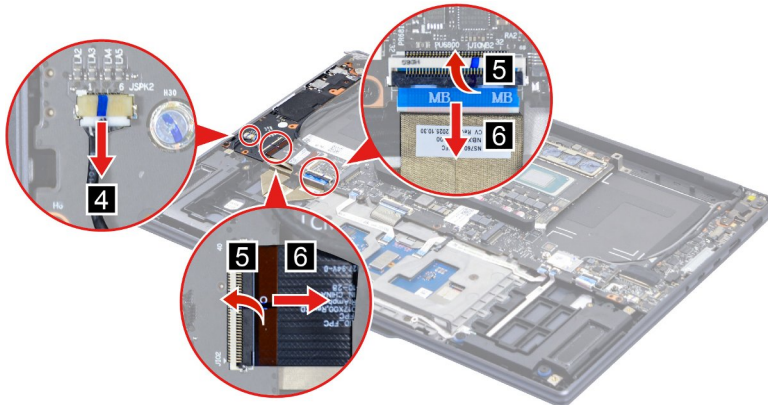

Figure 22. Disconnect the cables

Step 3. Remove one screw and then remove the I/O board.

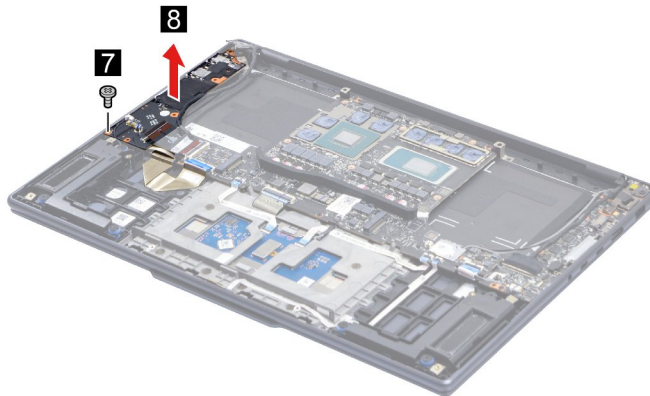

Figure 23. Remove one screw and remove the I/O board

Table 13. Screw used to secure the I/O board

Thread	Length (mm)	Torque (kgf.cm)	Quantity
M2	3.5	1.85 ± 0.15	1

Step 4. Remove the I/O FFC from the I/O board.

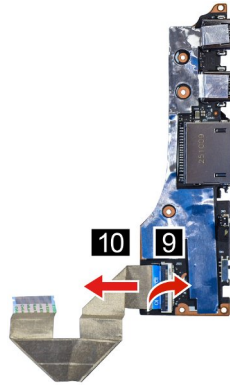

Figure 24. Remove the I/O FFC

Step 5. Install the I/O board and I/O FFC in reverse order.

---

## System board, I/O FPC and PMIC FFC

- Before you start, ensure that you have read Chapter 1 “Safety requirements for hardware maintenance” on page 1 and “General guidelines” on page 29.
- Make sure the following FRUs (or CRUs) have been removed.
  - “Lower case” on page 29
  - “Battery pack and battery pack cable” on page 31
  - “Wi-Fi card mylar” on page 32
  - “M.2 solid-state drive” on page 33
  - “PMIC board” on page 35
  - “Type-C bracket” on page 36
  - “Thermal module” on page 38

Step 1. Remove three screws and then open the hinge.

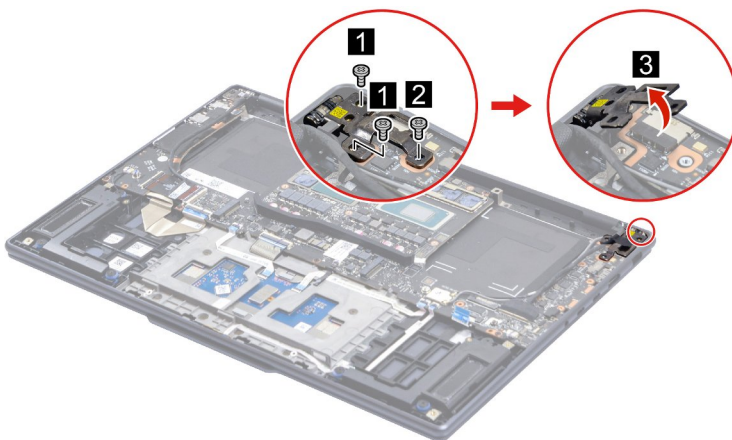

Figure 25. Remove three screws and open the hinge

Table 14. Screws used to secure the hinge

Label	Thread	Length (mm)	Torque (kgf.cm)	Quantity
<b>1</b>	M2.5	4.5	3.5 ± 0.3	2
<b>2</b>	M2	5	2.3 ± 0.15	1

Step 2. Disconnect cables connected to the system board.

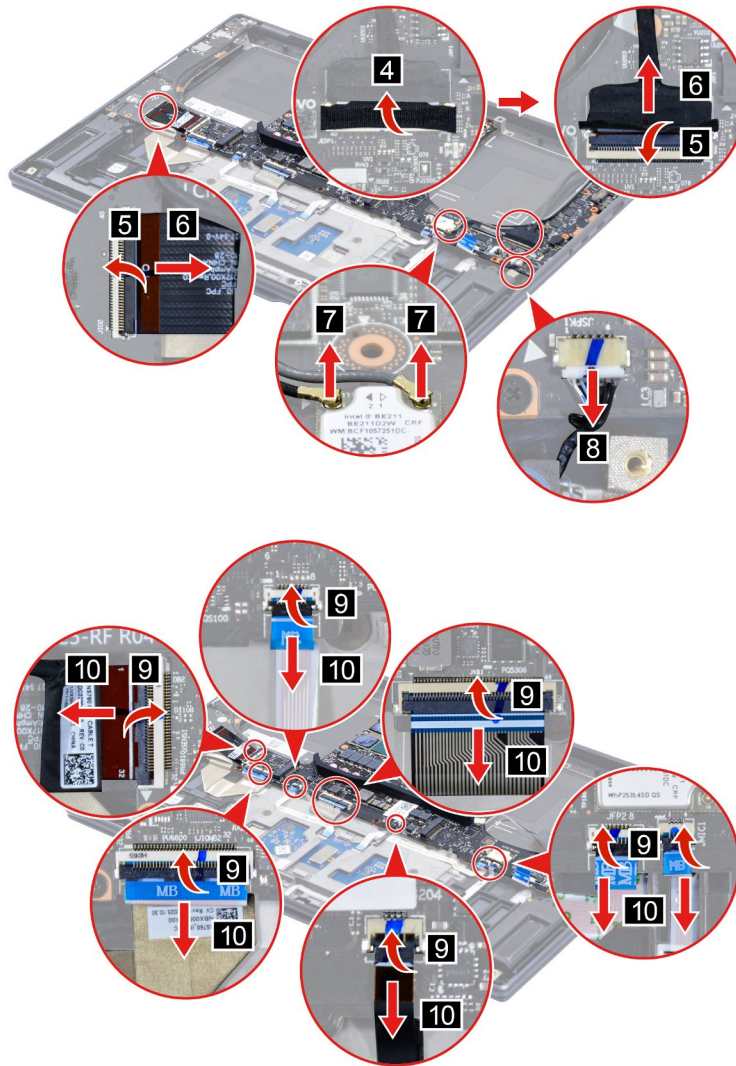

Figure 26. Disconnect cables

Step 3. Remove five screws and then remove the system board.

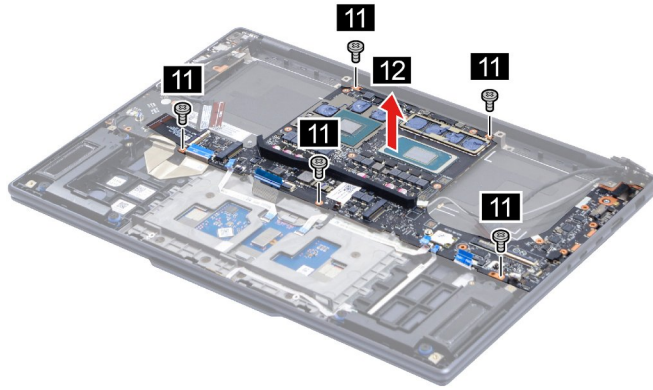

Figure 27. Remove five screws and remove the system board

Table 15. Screws used to secure the system board

Thread	Length (mm)	Torque (kgf.cm)	Quantity
M2	3.5	1.85 ± 0.15	5

Step 4. Disconnect the I/O FPC from the system board.

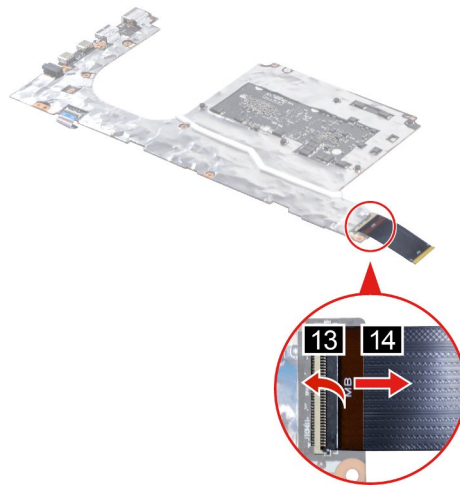

Figure 28. Disconnect the I/O FPC from the system board

Step 5. Disconnect the PMIC FFC from the system board.

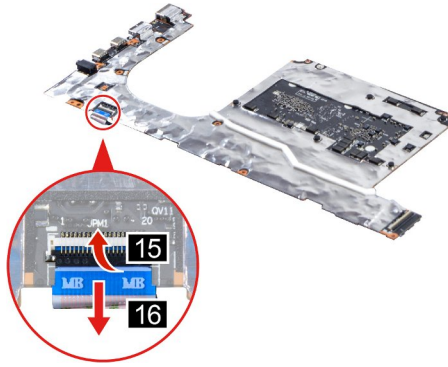

Figure 29. Disconnect the PMIC FFC from the system board

Step 6. Install the system board, I/O FPC and PMIC FFC in reverse order.

## Write key product information to a replacement system board

Some key product information and settings are stored in the ROMs of the PC's system board. The information and settings are essential for using and servicing a Lenovo PC. After replacing a system board for a Lenovo PC, you need to use a Lenovo-provided software tool to write key information—including machine type model (MTM), serial number (SN), and product name—as well as settings such as keyboard language to the replacement system board.

For service technicians, go to <https://support.lenovo.com/us/en/solutions/ht102004> for detailed instructions on how to create and use a Golden Key U1 tool or a normal BIOS tool.

For users, follow the following steps:

**Attention:** Take extra caution when entering the MTM and SN and when selecting the product name and keyboard language. Carefully verify these details before committing the writing action. Once recorded on the system board, they cannot be altered. Consult Lenovo service if you are uncertain about the MTM, SN, and product name for your PC.

- Step 1. Connect the ac power adapter and turn on the computer.
- Step 2. Download the tool package and double-click the WinMBDWizard.exe file to run the tool. To download the tool, go to <https://support.lenovo.com/solutions/HT516532>.
- Step 3. Follow the on-screen instructions to input the MTM and SN, select the product name and keyboard language of the computer.
- Step 4. Click **Start Update** to update the product information.
- Step 5. Click **Yes** in the confirmation window to continue the update.
- Step 6. Click **Finish** to close the tool.
- Step 7. Click **Yes** in the confirmation window to restart the computer and apply the configuration on the system board.

**Note:** Do not turn off the computer or disconnect the computer from ac power during the whole process.

---

## Speakers

- Before you start, ensure that you have read Chapter 1 “Safety requirements for hardware maintenance” on page 1 and “General guidelines” on page 29.

- Make sure the following FRUs (CRUs) have been removed.
  - “Lower case” on page 29
  - “Battery pack and battery pack cable” on page 31
  - “Wi-Fi card mylar” on page 32
  - “M.2 solid-state drive” on page 33
  - “PMIC board” on page 35
  - “Type-C bracket” on page 36
  - “Thermal module” on page 38
  - “I/O board and I/O FFC” on page 41
  - “System board, I/O FPC and PMIC FFC” on page 43

Step 1. Remove six screws and then remove the speakers.

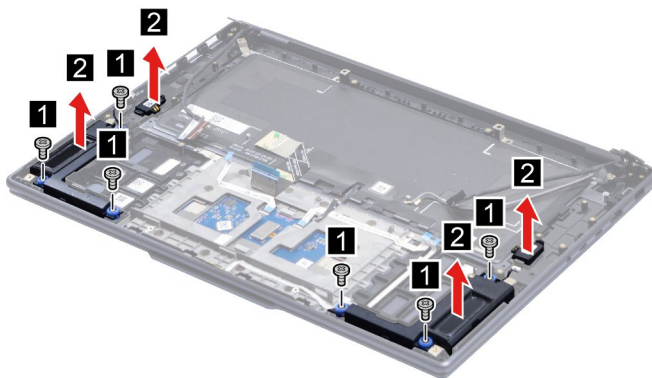

Figure 30. Remove the speakers

Table 16. Screws used to secure the speakers

Thread	Length (mm)	Torque (kgf.cm)	Quantity
M2	2	1.85 ± 0.15	6

Step 2. Install the speakers in reverse order.

## Display assembly

- Before you start, ensure that you have read Chapter 1 “Safety requirements for hardware maintenance” on page 1 and “General guidelines” on page 29.
- Make sure the following FRUs (or CRUs) have been removed.
  - “Lower case” on page 29
  - “Wi-Fi card mylar” on page 32

Step 1. Peel off the tapes and release the cables from cable guides.

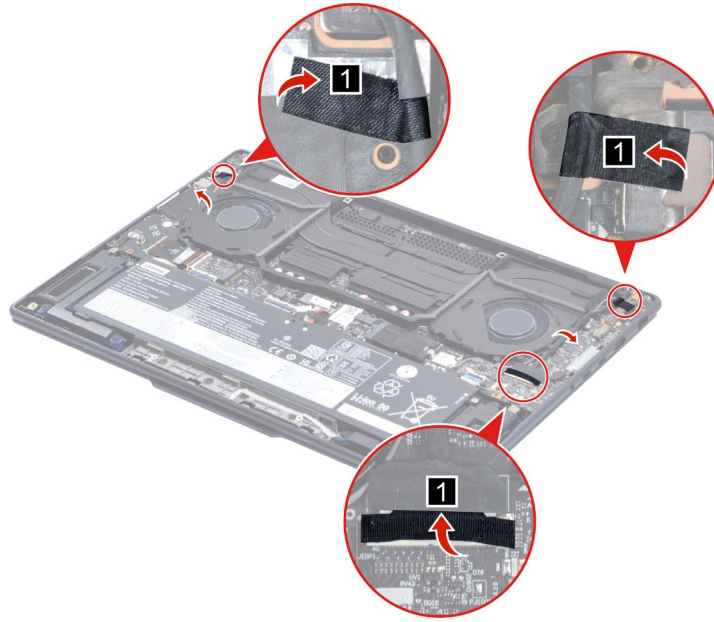

Figure 31. Peel off the tapes and release the cables from cable guides

Step 2. Disconnect the EDP cable and camera cable from the system board and then detach the main and auxiliary antenna cable connectors.

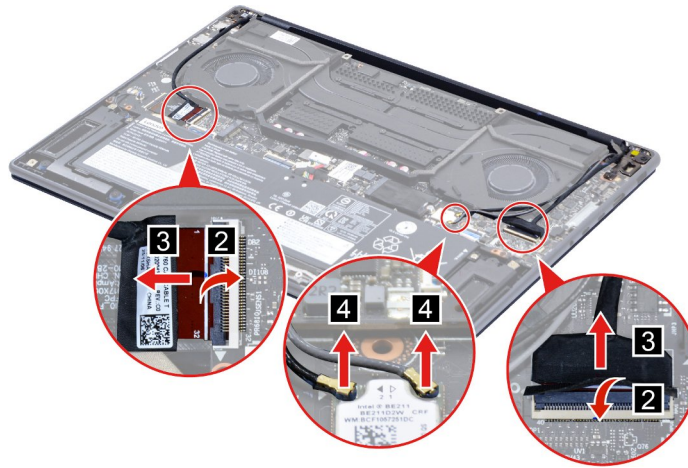

Figure 32. Disconnect cables and connectors

Step 3. Rotate the display assembly to an angle of more than 90 degrees and place the computer on a flat surface as shown. Remove six screws and then remove the display assembly.

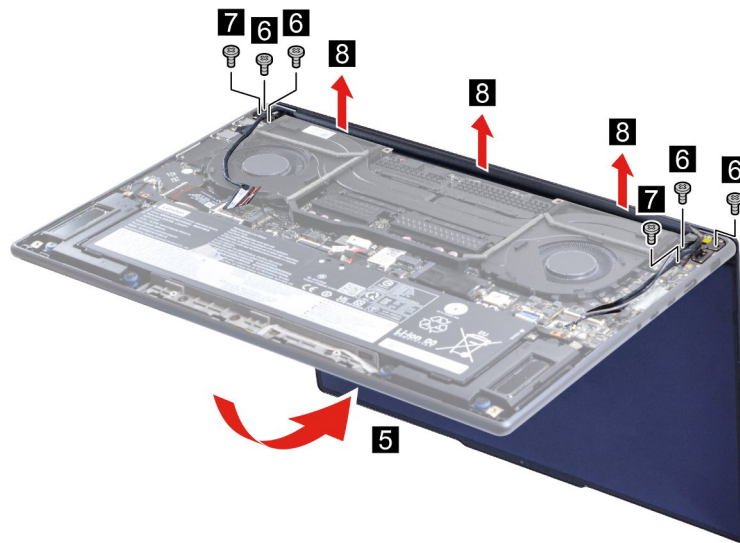

Figure 33. Remove the display assembly

Table 17. Screws used to secure the hinges

Label	Thread	Length (mm)	Torque (kgf.cm)	Quantity
<b>6</b>	M2.5	4.5	3.5 ± 0.3	4
<b>7</b>	M2	5	2.3 ± 0.15	2

**Notes:** For LCD panel with the factory color calibration feature, do the following to install new color profiles:

1. Connect your computer to the network.
2. Go to [https://pcsupport.lenovo.com/downloads/x\\_rite\\_color\\_tool](https://pcsupport.lenovo.com/downloads/x_rite_color_tool) to download the ColorTool.ZIP file.
3. Unzip to local drive and double-click the ColorTool.EXE file. Then, follow the on-screen instruction to input the display serial number and click “Submit”. When the new color profiles are installed successfully, all steps will be marked with “√”.
4. After LCD panel replacement, press Shift + Delete to permanently delete the ColorTool folder on customer’s device.

You will also find the instructions that come with the LCD panel.

Step 4. Install the display assembly in reverse order.

## LCD Self Test

When you turn on the computer and the LCD goes black, run LCD Self Test to help you determine whether the LCD functions normally.

To run LCD Self Test:

Ensure that the computer is connected to ac power. Then, press the power button for about seven seconds to turn off the computer.

Press Fn, left Ctrl, and the power button at the same time. If the computer displays five solid colors in sequence across the entire screen, it indicates that the LCD functions normally.

The test lasts for about 20 seconds and then exits automatically. You also can press the power button to exit the test.

---

## Upper case

- Before you start, ensure that you have read Chapter 1 “Safety requirements for hardware maintenance” on page 1 and “General guidelines” on page 29.
- Make sure the following FRUs (CRUs) have been removed.
  - “Lower case” on page 29
  - “Battery pack and battery pack cable” on page 31
  - “Wi-Fi card mylar” on page 32
  - “M.2 solid-state drive” on page 33
  - “PMIC board” on page 35
  - “Type-C bracket” on page 36
  - “Microphone board and microphone cable” on page 37
  - “Force pad FFC1 and force pad FFC2” on page 38
  - “Thermal module” on page 38
  - “I/O board and I/O FFC” on page 41
  - “System board, I/O FPC and PMIC FFC” on page 43
  - “Speakers” on page 46
  - “Display assembly” on page 47

Step 1. You can get the upper case after removing the FRUs (CRUs) above.

Step 2. Install the upper case in reverse order.

---

## Disassemble the display assembly

The display assembly as a whole is not a FRU. Instead, it contains FRUs as its components. Before disassembling the display assembly, make sure it has been detached from the upper case.

### Hinge cover

- Before you start, ensure that you have read Chapter 1 “Safety requirements for hardware maintenance” on page 1 and “General guidelines” on page 29.
- Make sure the following FRU (or CRU) has been removed.
  - “Display assembly” on page 47

Step 1. Remove the hinge cover.

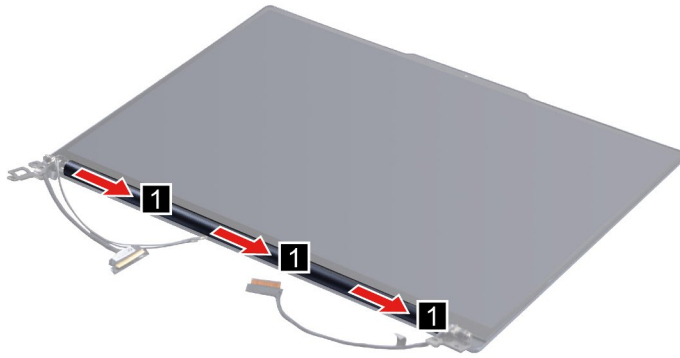

Figure 34. Remove the hinge cover

Step 2. Install the hinge cover in reverse order.

## Hinges

- Before you start, ensure that you have read Chapter 1 “Safety requirements for hardware maintenance” on page 1 and “General guidelines” on page 29.
- Make sure the following FRUs (CRUs) have been removed.
  - “Display assembly” on page 47
  - “Hinge cover” on page 50

Step 1. Remove six screws and then remove the hinges.

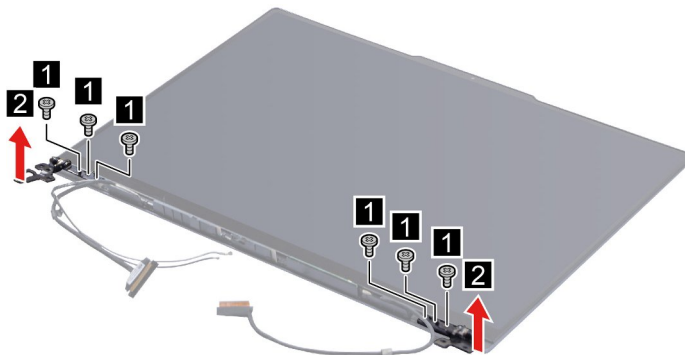

Figure 35. Remove the hinges

Table 18. Screws used to secure the hinges

Thread	Length (mm)	Torque (kgf.cm)	Quantity
M2	5	1.85 ± 0.15	6

Step 2. Install the hinges in reverse order.

## Strip cover

- Before you start, ensure that you have read Chapter 1 “Safety requirements for hardware maintenance” on page 1 and “General guidelines” on page 29.
- Make sure the following FRUs (or CRUs) have been removed.
  - “Display assembly” on page 47
  - “Hinge cover” on page 50

“Hinges” on page 51

Step 1. Remove the strip cover.

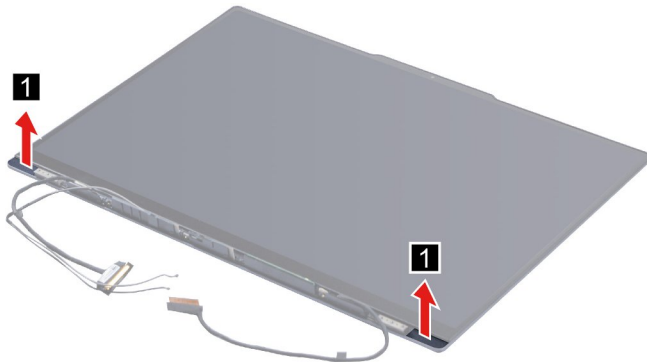

Figure 36. Remove the strip cover

Step 2. Install the strip cover in reverse order.

## Panel, EDP cable and removable tapes

- Before you start, ensure that you have read Chapter 1 “Safety requirements for hardware maintenance” on page 1 and “General guidelines” on page 29.
- Make sure the following FRUs (CRUs) have been removed.
  - “Display assembly” on page 47
  - “Hinge cover” on page 50
  - “Hinges” on page 51
  - “Strip cover” on page 51

Step 1. Remove two pieces of removable tape with tweezers carefully and then remove six screws.

**Note:** The removable tape is not reusable. Replace it when replacing related FRUs.

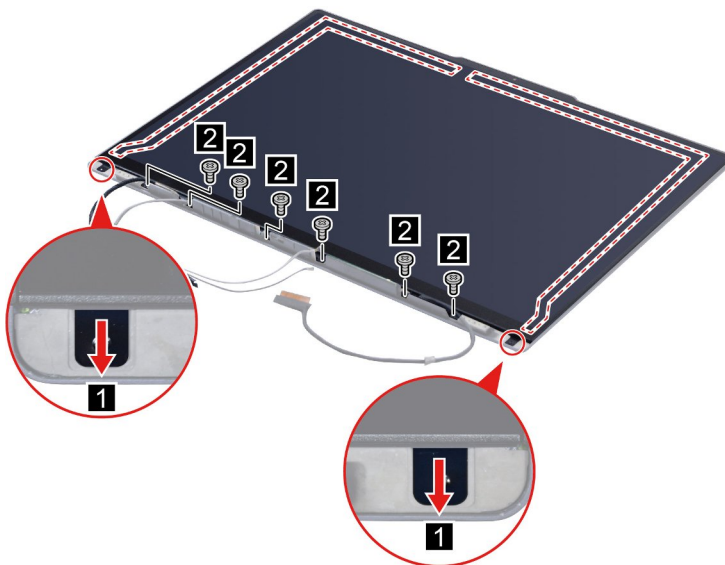

Figure 37. Remove removable tapes and six screws

Table 19. Screws used to secure the glass frame

Thread	Length (mm)	Torque (kgf.cm)	Quantity
M1.6	2.9	1.3 ± 0.15	6

Step 2. Detach the touch board cable from the panel and then remove the panel.

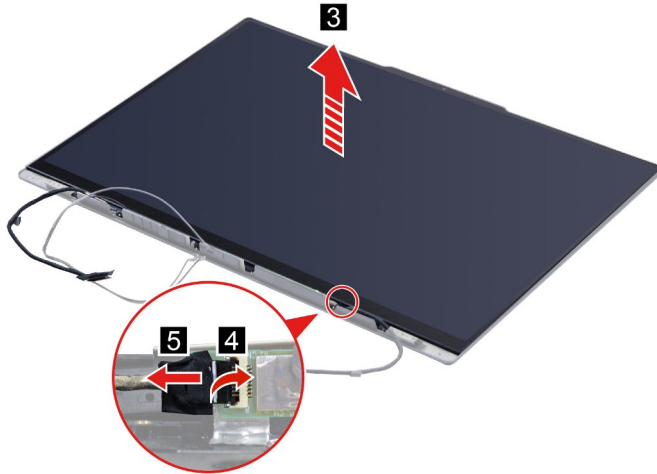

Figure 38. Remove the panel

Step 3. Peel off the tape and then remove the EDP cable from the panel.

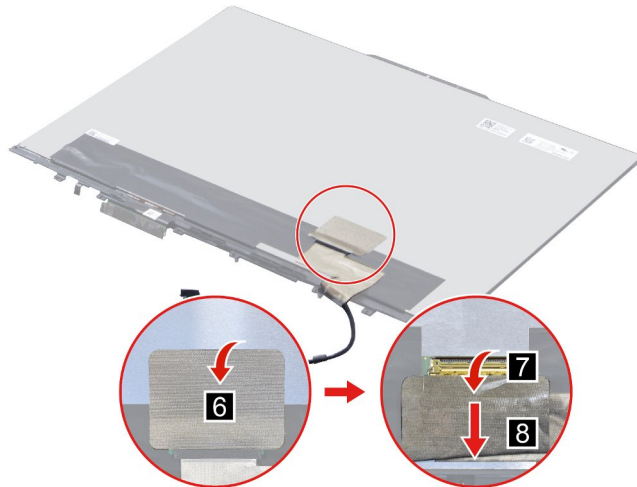

Figure 39. Remove the EDP cable from the panel

Step 4. Install the panel, EDP cable and removable tapes in reverse order.

## Camera rubber

- Before you start, ensure that you have read Chapter 1 “Safety requirements for hardware maintenance” on page 1 and “General guidelines” on page 29.
- Make sure the following FRUs (CRUs) have been removed.
  - “Display assembly” on page 47
  - “Hinge cover” on page 50
  - “Hinges” on page 51

“Strip cover” on page 51

“Panel, EDP cable and removable tapes” on page 52

Step 1. Remove the camera rubber.

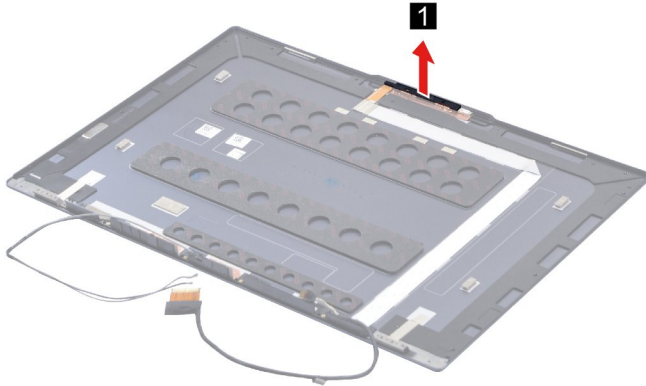

Figure 40. Remove the camera rubber

Step 2. Install the camera rubber in reverse order.

## Camera board

- Before you start, ensure that you have read Chapter 1 “Safety requirements for hardware maintenance” on page 1 and “General guidelines” on page 29.
- Make sure the following FRUs (CRUs) have been removed.
  - “Display assembly” on page 47
  - “Hinge cover” on page 50
  - “Hinges” on page 51
  - “Strip cover” on page 51
  - “Panel, EDP cable and removable tapes” on page 52
  - “Camera rubber” on page 53

Step 1. Disconnect camera cable from the camera board and then remove the camera board.

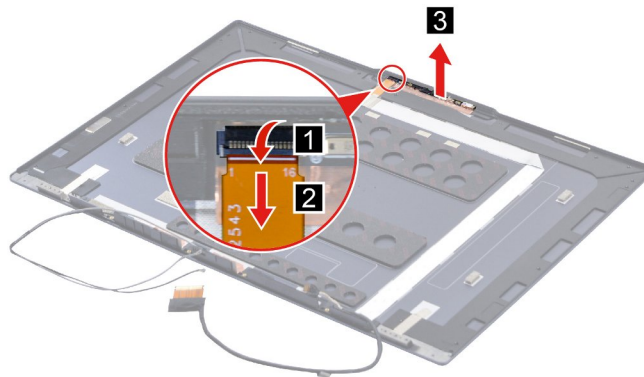

Figure 41. Remove the camera board

Step 2. Install the camera board in reverse order.

## Camera cable

- Before you start, ensure that you have read Chapter 1 “Safety requirements for hardware maintenance” on page 1 and “General guidelines” on page 29.
- Make sure the following FRUs (CRUs) have been removed.
  - “Display assembly” on page 47
  - “Hinge cover” on page 50
  - “Hinges” on page 51
  - “Strip cover” on page 51
  - “Panel, EDP cable and removable tapes” on page 52
  - “Camera rubber” on page 53

Step 1. Disconnect the camera cable from the camera board and then remove the camera cable.

**Note:** Remove one bar with tweezers carefully when removing the camera cable.

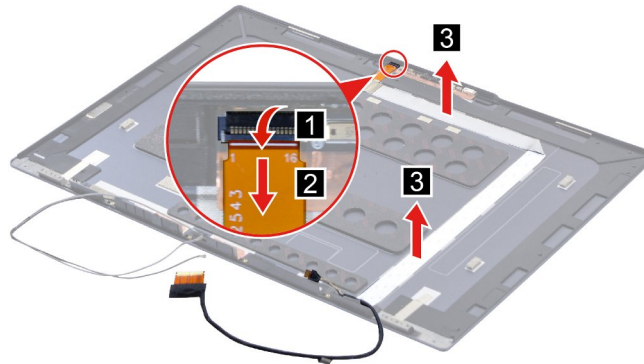

Figure 42. Remove the camera cable

Step 2. Install the camera cable in reverse order.

## Panel cover

- Before you start, ensure that you have read Chapter 1 “Safety requirements for hardware maintenance” on page 1 and “General guidelines” on page 29.
- Make sure the following FRUs (CRUs) have been removed.
  - “Display assembly” on page 47
  - “Hinge cover” on page 50
  - “Hinges” on page 51
  - “Strip cover” on page 51
  - “Panel, EDP cable and removable tapes” on page 52
  - “Camera rubber” on page 53
  - “Camera board” on page 54
  - “Camera cable” on page 55

Step 1. You can get the panel cover after removing the FRUs (CRUs) above.

Step 2. Install the panel cover in reverse order.

---

## Appendix A. Important notice for Quebec consumers

In regard to section 79.18 of Quebec's Regulation respecting the application of the Consumer Protection Act, Lenovo in no way guarantees the availability of (a) replacement parts; (b) repair services; and (c) information necessary to maintain or repair the goods. For up-to-date information on the technical support and parts available for your purchase, please consult <https://support.lenovo.com/ca/en>.

En ce qui concerne l'article 79.18 du Règlement d'application de la Loi sur la protection du consommateur du Québec, Lenovo ne garantit en aucune façon la disponibilité des éléments suivants : (a) les pièces de rechange ; (b) les services de réparation ; et (c) les renseignements nécessaires à l'entretien à la réparation du bien. Pour obtenir des renseignements à jour sur le soutien technique et les pièces disponibles pour votre achat, veuillez consulter <https://support.lenovo.com/ca/fr>.

---

## Appendix B. Self-help resources

Use the following self-help resources to learn more about the computer and troubleshoot problems.

Resources	How to access?
Troubleshooting and frequently asked questions	<ul style="list-style-type: none"><li>• <a href="https://www.lenovo.com/tips">https://www.lenovo.com/tips</a></li><li>• <a href="https://forums.lenovo.com">https://forums.lenovo.com</a></li></ul>
Accessibility information	<a href="https://www.lenovo.com/accessibility">https://www.lenovo.com/accessibility</a>
Reset or restore Windows	<ul style="list-style-type: none"><li>• Use Lenovo recovery options.<ol style="list-style-type: none"><li>1. Go to <a href="https://support.lenovo.com/HowToCreateLenovoRecovery">https://support.lenovo.com/HowToCreateLenovoRecovery</a>.</li><li>2. Follow the on-screen instructions.</li></ol></li><li>• Use Windows recovery options.<ol style="list-style-type: none"><li>1. Go to <a href="https://pcsupport.lenovo.com">https://pcsupport.lenovo.com</a>.</li><li>2. Detect your computer or manually select your computer model.</li><li>3. Click <b>Troubleshoot &amp; Diagnose</b> → <b>Custom Troubleshooting</b> → <b>Operating System Diagnostics</b> and then follow the on-screen instructions.</li></ol></li></ul>
Use Lenovo Vantage or Lenovo Baiying to: <ul style="list-style-type: none"><li>• Download and install the latest drivers and firmware.</li><li>• Configure hardware settings.</li><li>• Diagnose computer hardware problems.</li><li>• Check the computer warranty status.</li></ul>	Use Windows Search.
Product documentation: <ul style="list-style-type: none"><li>• <a href="#">Generic Safety and Compliance Notices</a></li><li>• <i>Safety and Warranty Guide</i></li><li>• <i>Setup Guide</i></li><li>• <i>User Guide</i></li><li>• This <i>Hardware Maintenance Manual</i></li><li>• <i>Regulatory Notice</i></li></ul>	Go to <a href="#">Lenovo Documentation Center</a> and search by product.

---

Resources	How to access?
Lenovo Support Web site with the latest support information on the following:	Visit <a href="https://support.lenovo.com">https://support.lenovo.com</a> .
<ul style="list-style-type: none"> <li>• Drivers and software</li> <li>• Diagnostic solutions</li> <li>• Product and service warranty</li> <li>• Product and parts details</li> <li>• Knowledge base and frequently asked questions</li> </ul>	
Windows help information	<ul style="list-style-type: none"> <li>• Use <b>Get Help</b> or <b>Tips</b>.</li> <li>• Use Windows Search.</li> <li>• Microsoft Support Web site: <a href="https://support.microsoft.com">https://support.microsoft.com</a></li> </ul>

---

## **Trademarks**

LENOVO and the LENOVO logo are trademarks of Lenovo.

All other trademarks are the property of their respective owners. © 2026 Lenovo.

**Lenovo**